



F420-D1 series

In line high pressure filters



Technical Information

Housing

Pressure: Max working 420 bar (6000 psi) (acc. to NFPA T 3.10.5.1)
Burst 1260 bar (18300 psi) (acc. to NFPA T 3.10.5.1)

Connection Ports: 1/2" ÷ 1 1/2" BSP (other thread options on request)
3/4" ÷ 1 1/2" SAE J518-6000

Materials: Head: cast iron
Bowl: extruded steel
Seal: Buna-N (FKM on request)

By-pass: No by-pass or 6 bar (90 psi) setting

Element

Filter Media: Microglass fiber 4,5 – 7 – 12 – 18 - 27 $\mu\text{m}_{(c)}$ (acc. to ISO 16889)
Cellulose 10 - 25 $\mu\text{m}_{(c)}$ (acc. to ISO 16889)

Differential collapse pressure:
21 bar (300 psi) or 210 bar (3000 psi) (acc. to ISO 2941)

Filtrec elements are tested also according to ISO 2942 and ISO 23181

Common

Working temperature: -25°C +120°C (-13°F +248°F)

Fluid compatibility (acc. to ISO 2943):
Full with HH-HL-HM-HV (acc. to ISO 6743/4).
For use with other fluid applications please contact Filtrec Customer Service (info@filtrec.it).

Ordering information

MEDIA	
000	no element
G03	microglass fiber $\beta_{4,5 \mu\text{m} (c)} \geq 1000$
G06	microglass fiber $\beta_{7 \mu\text{m} (c)} \geq 1000$
G10	microglass fiber $\beta_{12 \mu\text{m} (c)} \geq 1000$
G15	microglass fiber $\beta_{18 \mu\text{m} (c)} \geq 1000$
G25	microglass fiber $\beta_{27 \mu\text{m} (c)} \geq 1000$
*C10	cellulose $\beta_{10 \mu\text{m} (c)} \geq 2$
*C25	cellulose $\beta_{20 \mu\text{m} (c)} \geq 2$

*Only for Δp 21 bar (300 psi)

	NOMINAL SIZE	MEDIA	ELEMENT COLLAPSE	SEALS	CONNECTION	BY-PASS	INDICATOR PORT OPTION	INDICATOR
Filter assembly F420-D1	30	G10	A	V	B5	D	W	V05
Filter element D-1	30	G10	A	V				

ELEMENT COLLAPSE	
A	21 bar / 300 psi
*B	210 bar / 3000 psi

* recommended with no by-pass option.

SEALS	
B	NBR
V	FKM

CONNECTION	
B3	1/2" BSP
B4	3/4" BSP
B5	1" BSP
B6	1 1/4" BSP
B7	1 1/2" BSP
H4M	3/4" SAE J518-6000 - flange
H5M	1" SAE J518-6000 - flange
H6M	1 1/4" SAE J518-6000 - flange
H7M	1 1/2" SAE J518-6000 - flange

For different thread options please check availability with Filtrac Customer Service.

BY-PASS	
0	no by-pass
D	6 bar / 90 psi

INDICATOR PORT OPTION	
T	indicator port, plugged
W	indicator port without plug

INDICATOR	
000	no indicator
V05	differential visual 5 bar/ 70 psi
E05	differential electrical 5 bar/ 70 psi
V08	differential visual 8 bar/ 120 psi
E08	differential electrical 8 bar/ 120 psi

TO BE USED WITH NO BY-PASS OPTION ONLY

Overall dimensions

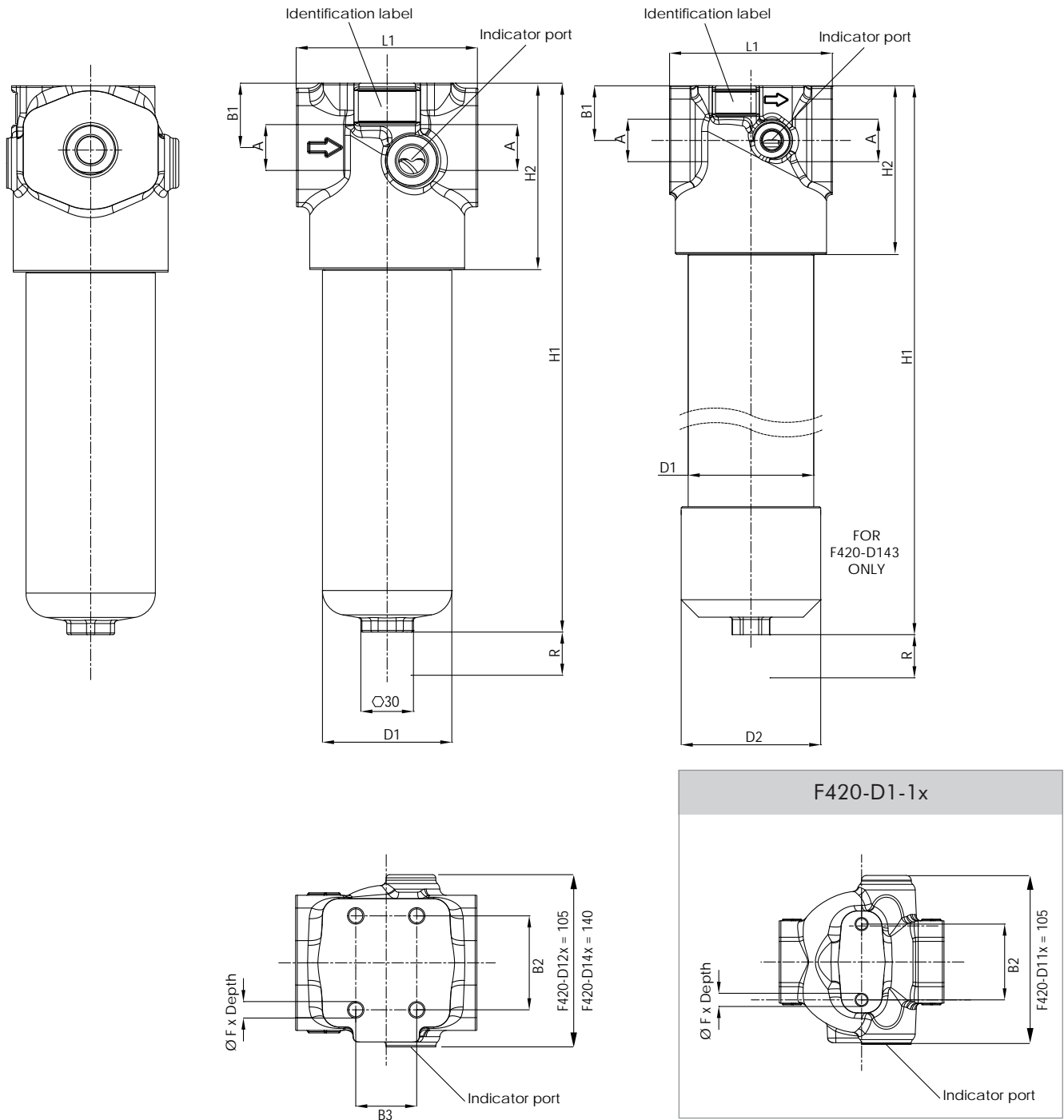

Nominal size

CODE	A	B1	B2	B3	D1	D2	F	H1	H2	L1	R	WEIGHT
F420-D110	1/2" BSP 3/4" BSP	27	46	-	70	-	M8x15	183	103	100	130	4,1Kg
F420-D111		27	46	-	70	-	M8x15	210		100	130	4,4 Kg
F420-D112		27	46	-	70	-	M8x15	303		100	130	5,4 Kg
F420-D120	3/4" BSP - flange 1" BSP - flange	39	57	37	78,5	-	M10x18	222	113	110	130	6,7 Kg
F420-D121		39	57	37	78,5	-	M10x18	333		110	130	8,4 Kg
F420-D124		39	57	37	78,5	-	M10x18	268		110	130	7,4 Kg
F420-D140	1" BSP 1"1/4 BSP - flange 1"1/2 BSP - flange	47	76	64	108	-	M12x22	262	145	140	140	13,2 Kg
F420-D141		47	76	64	108	-	M12x22	355		140	140	15,5 Kg
F420-D142		47	76	64	108	-	M12x22	475		140	140	18,4 Kg
F420-D143		47	76	64	108	120	M12x22	568		140	140	22,8 Kg

For alternative version, types and dimensions, see page 8

Pressure drop diagrams

The total Pressure Drop (Δp) value is obtained by adding the Δp values of filter housing and filter element at the given flow rate. This ideally should not exceed 1,0 bar (14,5 psi) and should never exceed 1/3 of the set value of the by-pass valve.

PRESSURE DROP THROUGH THE FILTER HOUSING

The Pressure Drop through the filter housing is governed by the port, not the bowl length and the oil viscosity.

PRESSURE DROP THROUGH THE CLEAN FILTER ELEMENT

The Pressure Drop through the filter element is related both to the internal diameter of the filter element and to the filter media; this value is affected by the oil viscosity in a roughly proportional way: e.g. when the Δp value from the curve is 0,2 bar and a 46 cSt oil is used, the corresponding value is 0,31 ($=0,2 \times 46/30$) bar.

Housing F420-D11...

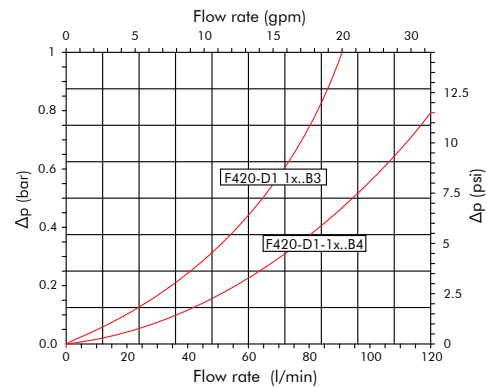

Element D110---A

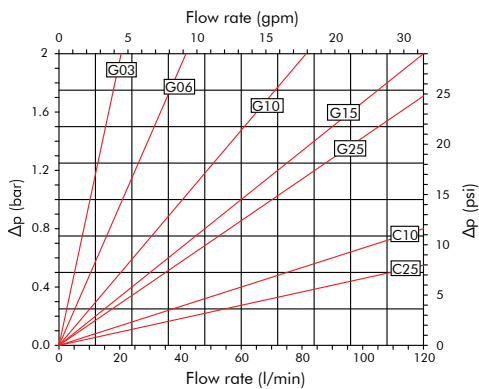

Element D110---B

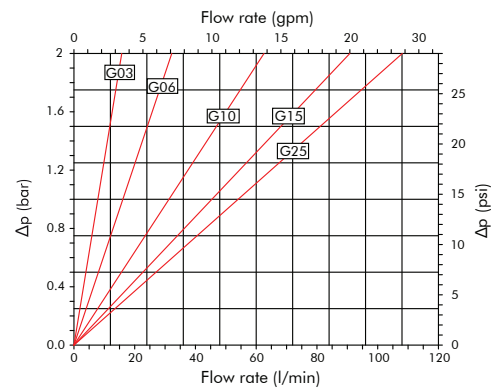

Element D111---A

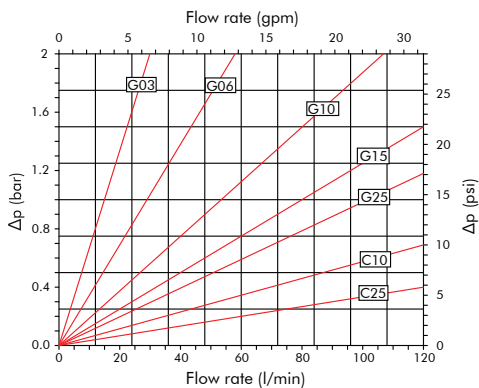

Element D111---B

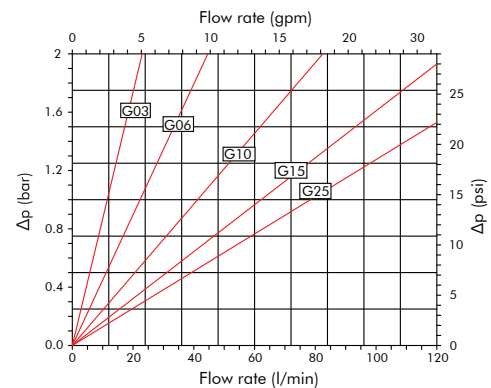

Element D112---A

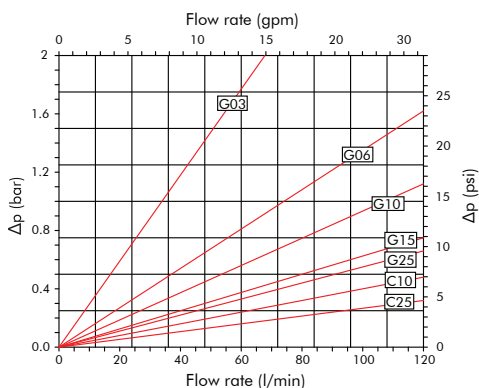

Element D112---B

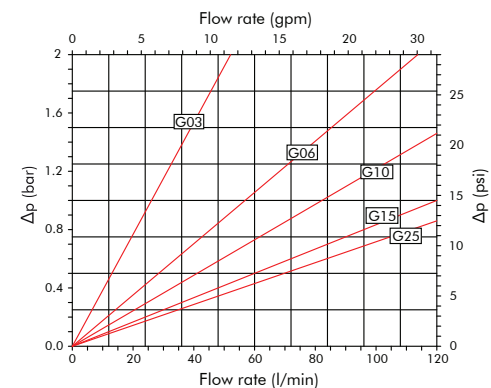

Pressure drop diagrams

PRESSURE DROP THROUGH THE FILTER HOUSING

The Pressure Drop through the filter housing is governed by the port, not the bowl length and the oil viscosity.

PRESSURE DROP THROUGH THE CLEAN FILTER ELEMENT

The Pressure Drop through the filter element is related both to the internal diameter of the filter element and to the filter media; this value is affected by the oil viscosity in a roughly proportional way: e.g. when the Δp value from the curve is 0,2 bar and a 46 cSt oil is used, the corresponding value is 0,31 ($=0,2 \times 46/30$) bar.

Housing F420-D12/D13...

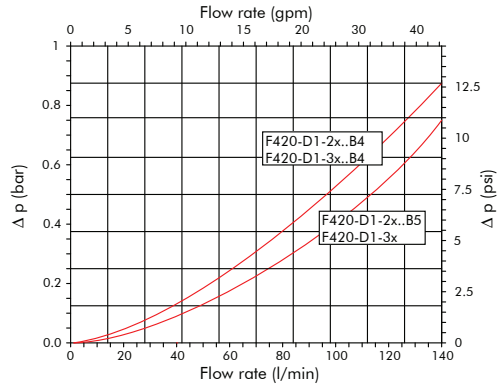

Element D120...-A

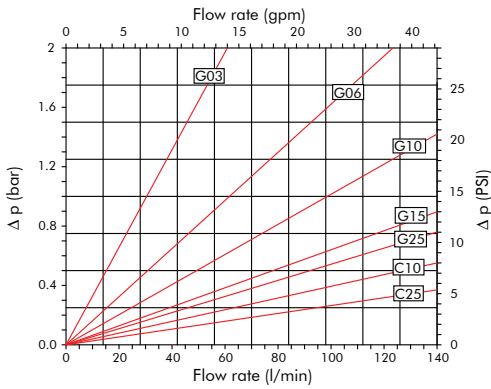

Element D120...-B

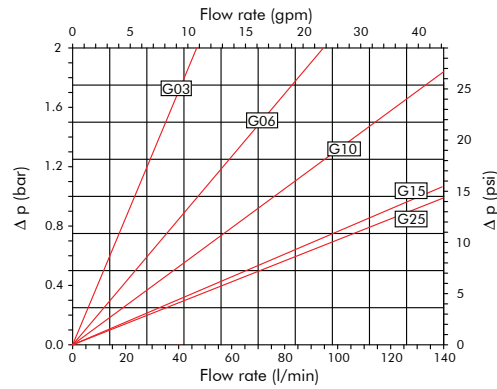

Element D121...-A

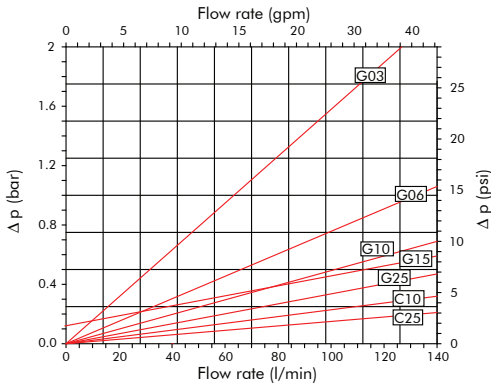

Element D121...-B

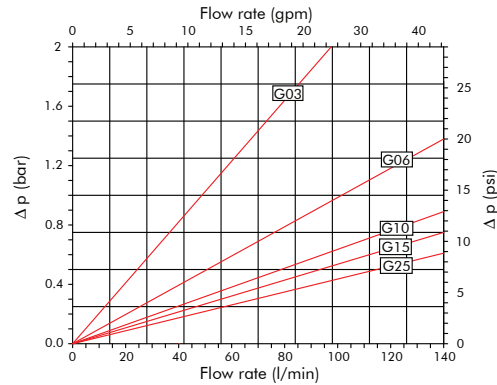

Pressure drop diagrams

PRESSURE DROP THROUGH THE FILTER HOUSING

The Pressure Drop through the filter housing is governed by the port, not the bowl length and the oil viscosity.

PRESSURE DROP THROUGH THE CLEAN FILTER ELEMENT

The Pressure Drop through the filter element is related both to the internal diameter of the filter element and to the filter media; this value is affected by the oil viscosity in a roughly proportional way: e.g. when the Δp value from the curve is 0,2 bar and a 46 cSt oil is used, the corresponding value is 0,31 (=0,2 x 46/30) bar.

Housing F420-D14/D15...

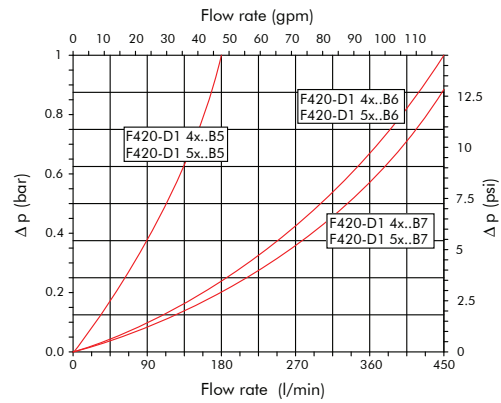

Element D140---A

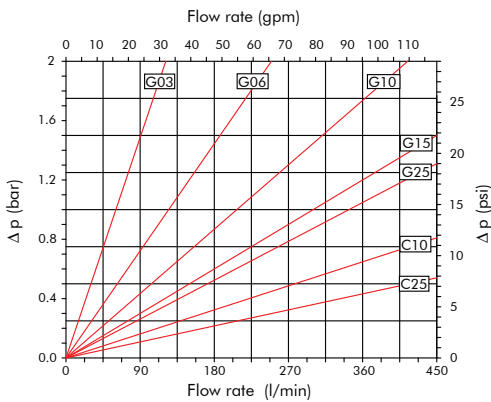

Element D140---B

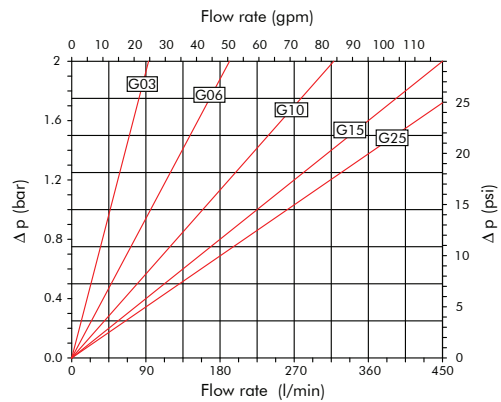

Element D141---A

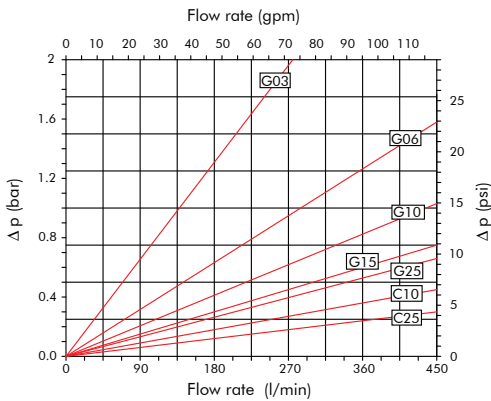

Element D141---B

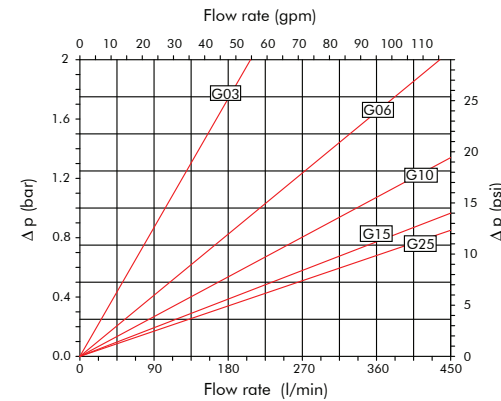

Element D142---A

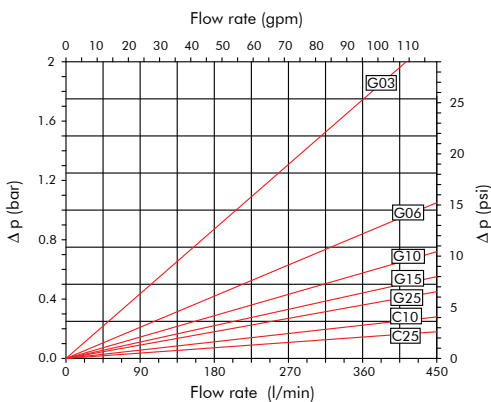

Element D142---B

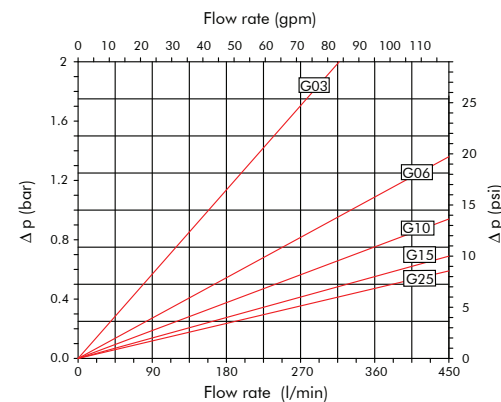

Pressure drop diagrams

Element D143...-A

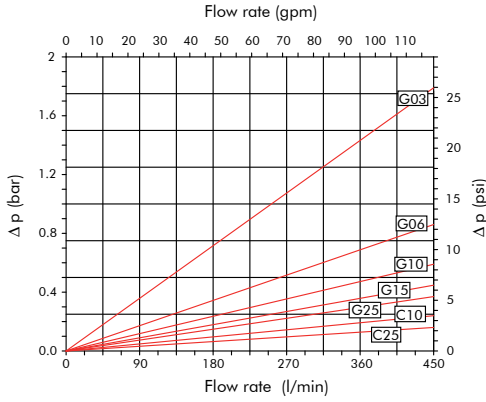

Element D143...-B

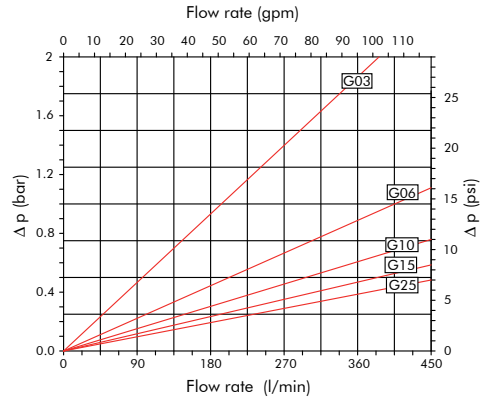

Element D154...-A

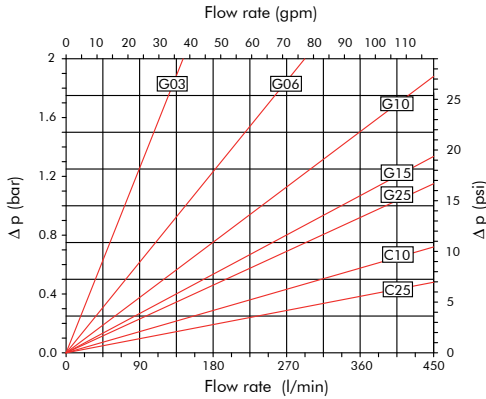

Element D154...-B

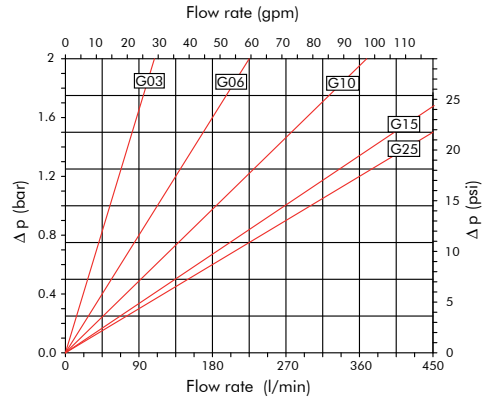

PRESSURE DROP THROUGH THE BY-PASS VALVE

The by-pass valve is a safety device to prevent element collapse in case of differential pressure peaks due to flow peaks, cold start conditions or when the clogged element is not replaced in a timely manner.

By-pass F420-1...

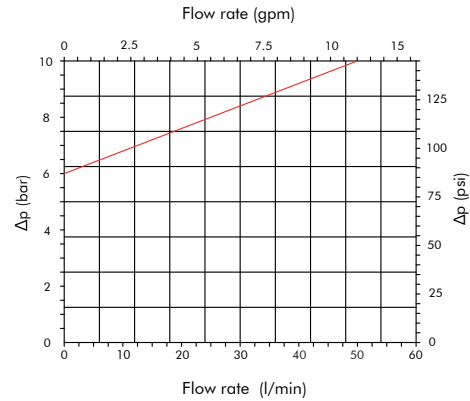

By-pass F420-2...

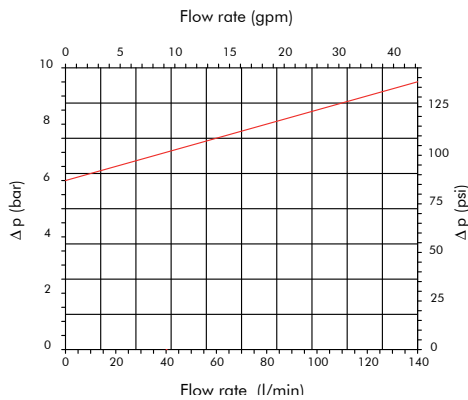

By-pass F420-4...

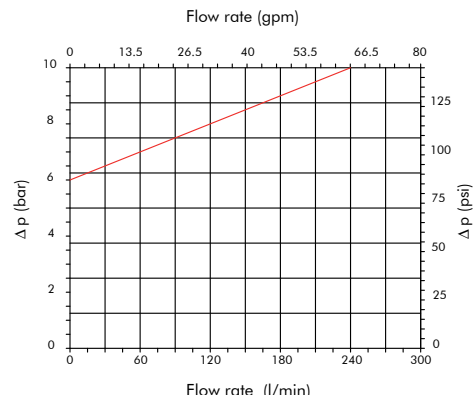

The above diagrams have been obtained at the FILTREC laboratory, according to the ISO 3968 specification, with mineral oil having 30 cSt viscosity and 0,86 Kg/dm3 density.

In case of discrepancy, please check contamination level, viscosity and features of the oil in use and the sampling points of the differential pressure.

Filter Elements

The F420 series is usually equipped with filter elements according to a widely accepted (US based) industry standard, having the dimensions listed here below.

Element	A	B	C
D110	45	25,5	86
D111	45	25,5	113
D112	45	25,5	209
D120	50	24,5	116
D121	50	24,5	209
D124	50	24,5	159
D140	78	43,2	116
D141	78	43,2	209
D142	78	43,2	329
D143	78	43,2	428

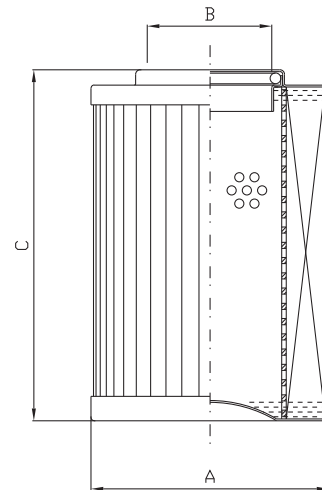

Alternative version

The F420 series can be optionally equipped with filter elements according to a different standard (European based), having the dimensions listed here below.

Their performances are corresponding to the standard version as indicated in the table, where you can see also the different filter housing lengths if applicable.

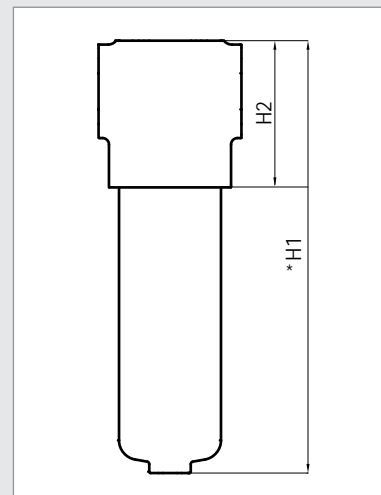

Element	A	B	C	Delta P diagram	Housing dimensions except *H1	*H1	H2
D130	53	27,5	120	see D120	see D120	222	113
D131	53	27,5	230	see D121	see D121	333	
D150	78	40,5	116	see D140	see D140	262	145
D151	78	40,5	235	see D141	see D141	394	
D152	78	40,5	375	see D142	see D142	543	
D153	78	40,5	520	see D143	see D143	660	
D154	78	40,5	140	see diagram	see D141	317	

User Tips

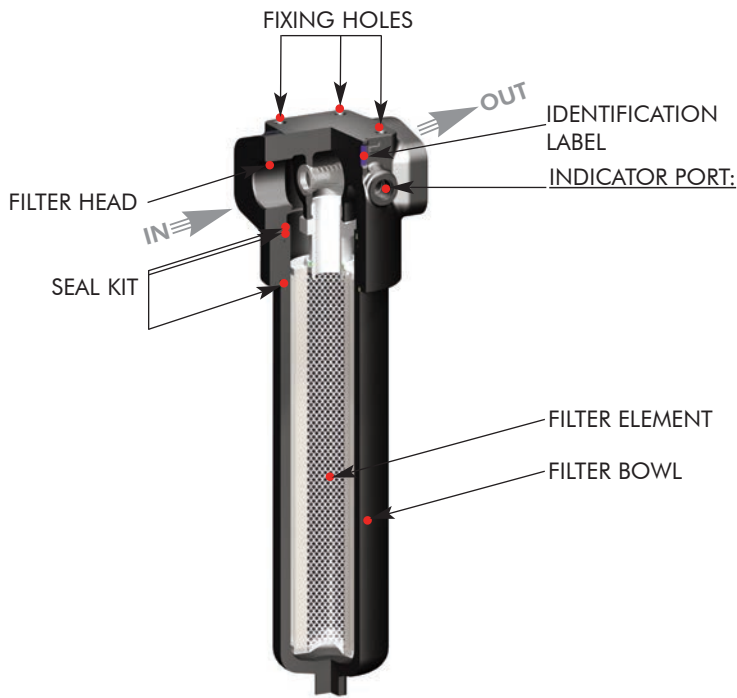

SPARE SEAL KIT PART NUMBER		
	NBR	FKM
F420-D1-10	06.021.00090	06.021.00135
F420-D1-20/30	06.021.00131	06.021.00136
F420-D1-40/50	06.021.00095	06.021.00137

BOWL TIGHTENING TORQUE	
F420-D1-10	65 Nm
F420-D1-20/30	75 Nm
F420-D1-40/50	90 Nm

INDICATOR TIGHTENING TORQUE	
V05/E05/V08/E08	50 Nm

Installation

Make sure that the filter is connected in the correct IN-OUT flow direction (shown by an arrow on the filter head).

The filter housing should be preferably mounted with the bowl downward; the filter head should be properly secured using the threaded fixing holes on the filter head; verify that no tension is present on the filter after mounting.

Make sure that enough space is available for element replacement and that the clogging indicator is in a easily viewable position. If an electrical indicator is used, make sure that it is properly wired.

Never run the system without a filter element fitted. We recommend the stocking of a spare FILTREC filter element for timely replacement when required.

Operation

Make sure that the filter works within the conditions of pressure, temperature and fluid compatibility given in the first page of this data sheet.

The filter element must be replaced as soon as the clogging indicator signals at working temperature (in cold start conditions, oil temperature lower than 30°C, a false alarm can be given due to oil viscosity).

If no clogging indicator is mounted, make sure that the filter element is replaced according to the system manufacturer's recommendations.

Maintenance

Before opening the filter housing, ensure that the system is switched off and there is no residual pressure in the filter.

Unscrew the bowl by turning it anticlockwise.

Remove the dirty filter element pulling it carefully; replace it with a FILTREC element, verifying the part number, particularly concerning the micron rating. When fitting the new element, open the plastic protection on the top and insert the element over the spigot in the filter head, then remove completely the plastic protection.

Clean carefully the bowl; check the gaskets conditions and replace if necessary; when replacing the bowl's gaskets ensure that the back-up ring is located below the O-ring and it is in the right verso (concave side up), lubricate the threads and screw by hand the bowl in the filter head by turning it clockwise. Tighten at the recommended torque.

N.B. The used filter elements cannot be cleaned and re-used.

PED Compliance

F420-D1 filters conform to PED 97/23/CE norm, article 3 section 3, and so they can be used with fluids of group 2 (liquids with steam pressure < 0,5 bar at the maximum allowable temperature, article 3, section 1.1(b) – sub-section II).

WARNING

Make sure that Personal Protective Equipment (PPE) is worn during installation and maintenance operation.

Disposal of filter elements

The used filter elements and the filter parts dirty of oil are classified as "Dangerous waste material": they must be disposed according to the local laws by authorized Companies.



F420-D1 series

www.filtrec.com

