



FCR-7 series

Return filters, tank top mounting, inside-to-outside filtration



Technical Information

Housing

Pressure: Max working 8 bar (116 psi) (acc. to NFPA T 3.10.5.1)
Burst 16 bar (232 psi) (acc. to NFPA T 3.10.5.1)

Connection Ports: 1/2" ÷ 2" BSP (other thread options on request)

Materials: Head and top cover: aluminium alloy
Top cover (sizes 10 to 14 only): nylon
Insert holder: aluminium alloy
Diffuser: zinc plated steel
Seal: Buna-N (FKM on request)

By-pass: 1,7 bar (24.6 psi)

Element

Filter Media: Microglass fiber 4,5 - 7 - 12 - 27 $\mu\text{m(c)}$ (acc. to ISO 16889)
Cellulose 10 - 25 $\mu\text{m(c)}$ (acc. to ISO 16889)
Wire mesh 60 μm

Differential burst pressure: 10 bar (145 psi) (acc. to ISO 2941)

Filtrec elements are tested also according to ISO 2942, ISO 23181 and ISO 3968

Common

Working temperature: -25°C +120°C (-13°F +248°F)

Fluid compatibility (acc. to ISO 2943):
Full with HH-HL-HM-HV (acc. to ISO 6743/4).
For use with other fluid applications please contact Filtrec Customer Service (info@filtrec.it).

MEDIA	
000	no element
G03	microglass fiber $\beta_{4,5 \mu\text{m (c)}} \geq 1000$
G06	microglass fiber $\beta_{7 \mu\text{m (c)}} \geq 1000$
G10	microglass fiber $\beta_{12 \mu\text{m (c)}} \geq 1000$
G25	microglass fiber $\beta_{18 \mu\text{m (c)}} \geq 1000$
C10	cellulose $\beta_{10 \mu\text{m (c)}} \geq 2$
C25	cellulose $\beta_{25 \mu\text{m (c)}} \geq 2$
T60	wire mesh 60 μm

Ordering information

	NOMINAL SIZE	MEDIA	SEALS	CONNECTION	BY-PASS	MAGNETS	DIFFUSOR	FILLING PLUG	INDICATOR POSITION	INDICATOR
Filter assembly FCR-7	30	G10	B	B7	B	M	S	T	C	R9
Filter element R-7	30	G10								

SEALS	
B	NBR (omit for spare element)
V	FKM

CONNECTION	
B3	1/2" BSP
B4	3/4" BSP
B5	1" BSP
B6	1 1/4" BSP
B7	1 1/2" BSP
B8	2" BSP

For different thread options please check availability with Filtrac Customer Service.

BY-PASS	
B	1,7 bar / 24,6 psi

MAGNETS	
0	no magnet
M	with magnets

DIFFUSOR	
0	no diffusor
S	with diffusor

FILLING PLUG	
0	no filling plug
T	with filling plug

INDICATOR POSITION	
0	no indicator - no hole
C	on the cover plug

INDICATOR	
000	no indicator
R6	visual pressure 1,3 bar / 18,9 psi
R7	pressure vacuum gauge -1 ÷ 5 bar / -14,5 ÷ 72,5 psi
R9	pressure gauge 0 ÷ 4 bar / 0 ÷ 58 psi
R10	pressure gauge 0 ÷ 4 bar / 0 ÷ 58 psi
R13	pressure switch SPDT 1,3 bar / 18,9 psi

 Preferential option

Overall dimensions

FCR-7 11 / 12 / 13 / 14

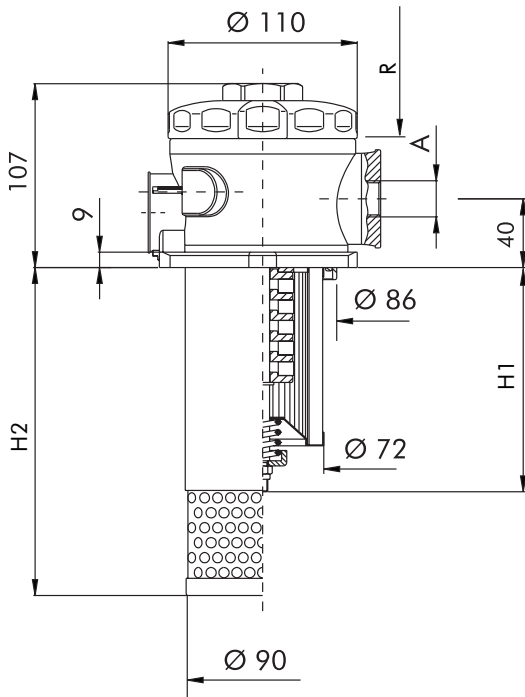

option "S" with diffusor option "0" without diffusor

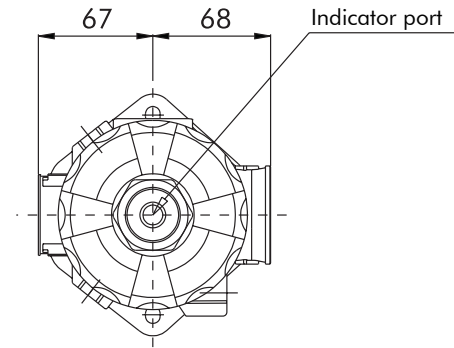

TANK MOUNTING PATTERN

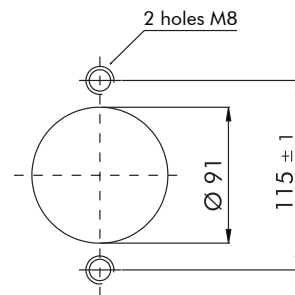

FCR-7 20 / 21 / 22

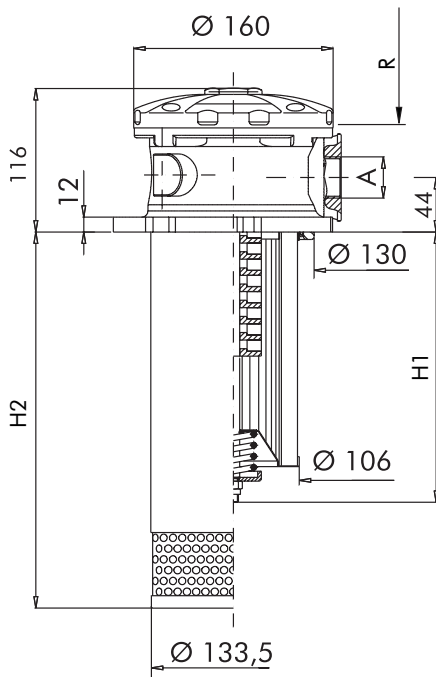

option "S" with diffusor / option "0" without diffusor

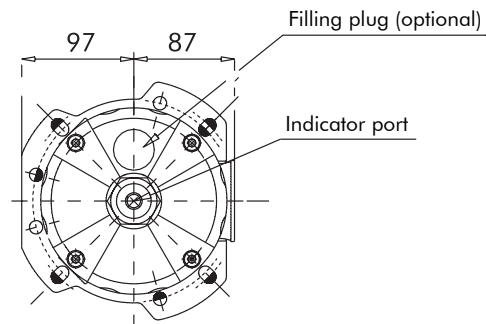

MULTIFIX FLANGE ALLOWING TWO TANK MOUNTING PATTERNS

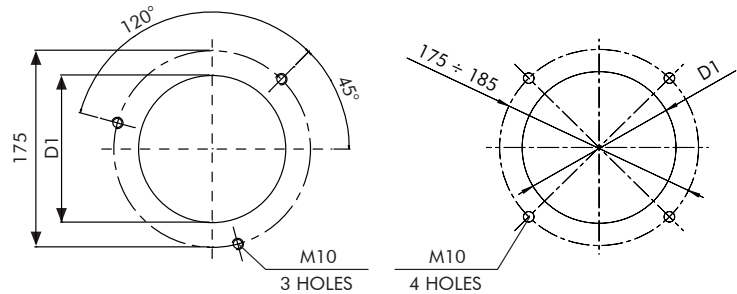

$D1 = 134$ for option "S" / 131 for option "0"

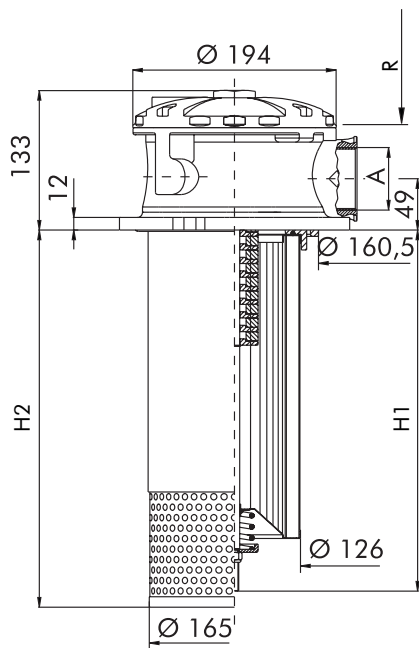

option "S" with diffuser / option "0" without diffuser

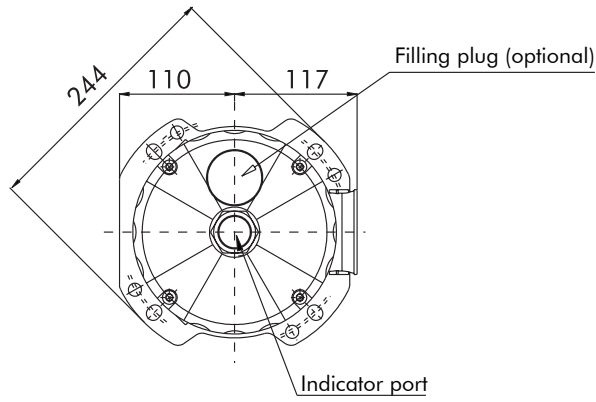

MULTIFIX FLANGE ALLOWING TWO TANK MOUNTING PATTERNS

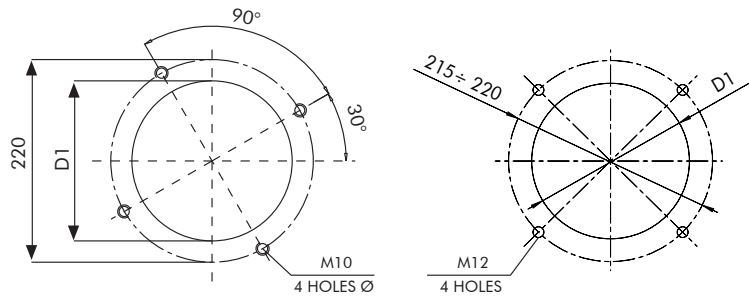

D1 = 166 for option "S" / 161 for option "0"

Nominal size

CODE	A	H1	H2	R	WEIGHT
FCR-7-11	1/2" BSP	133	195	206	2 Kg
FCR-7-12	3/4" BSP	178	195	250	2,2 Kg
FCR-7-13	1" BSP	228	345	300	2,4 Kg
FCR-7-14	1" 1/4 BSP	328	345	400	2,8 Kg
FCR-7-20	1" BSP	233	310	330	5,3 Kg
FCR-7-21	1" 1/4 BSP	303	310	400	5,6 Kg
FCR-7-22	1" 1/2 BSP	508	515	610	6,9 Kg
FCR-7-30	1" 1/2 BSP 2" BSP	265	360	380	7,2 Kg
FCR-7-31		345	360	460	7,5 Kg
FCR-7-32		535	550	650	9,1 Kg
FCR-7-33		445	550	560	9,8 Kg

For different thread options please contact Filtrec Customer Service.

Pressure drop diagrams

The total Pressure Drop (Δp) value is obtained by adding the Δp values of filter housing and filter element at the given flow rate. This ideally should not exceed 0,5 bar (7,3 psi) and should never exceed 1/3 of the set value of the by-pass valve.

PRESSURE DROP THROUGH THE FILTER HOUSING

The Pressure Drop through the filter housing is governed by the port, not the bowl length and the oil viscosity.

PRESSURE DROP THROUGH THE CLEAN FILTER ELEMENT

The Pressure Drop through the filter element is related both to the internal diameter of the filter element and to the filter media; this value is affected by the oil viscosity in a roughly proportional way: e.g. when the Dp value from the curve is 0,2 bar and a 46 cSt oil is used, the corresponding value is 0,31 ($=0,2 \times 46/30$) bar.

Housing FCR-7- 11/12/13/14

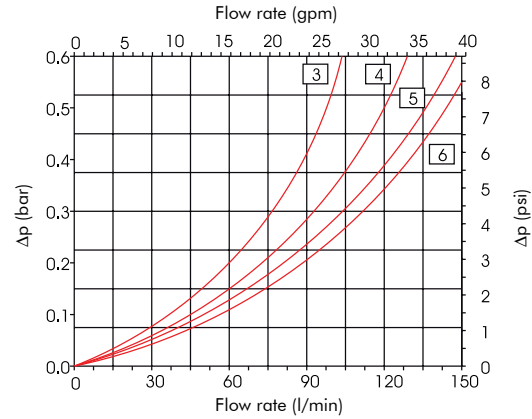

Element R-7-11

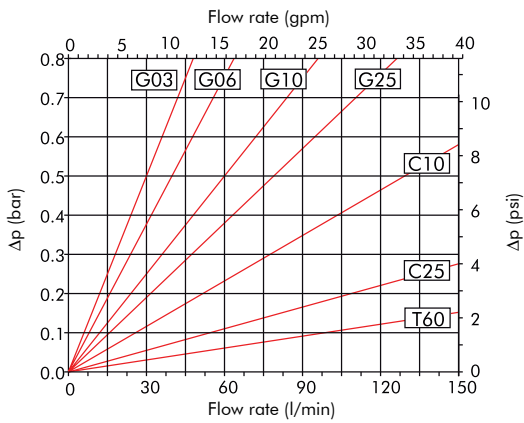

Element R-7-12

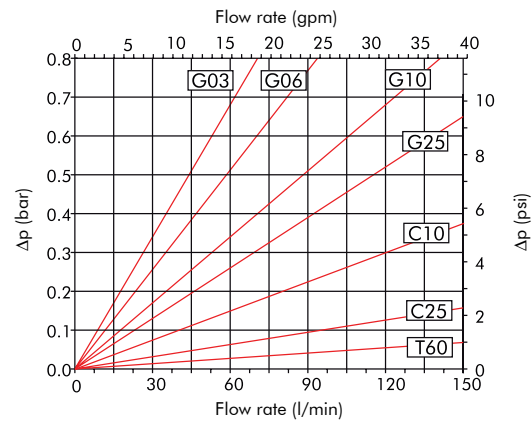

Element R-7-13

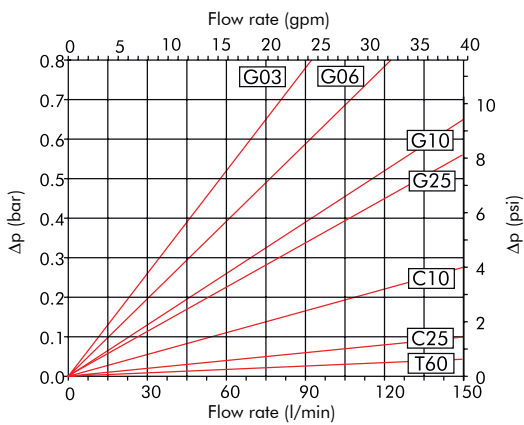

Element R-7-14

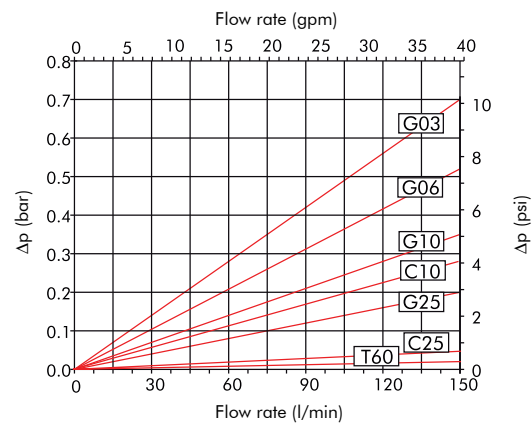

Pressure drop diagrams

PRESSURE DROP THROUGH THE FILTER HOUSING

The Pressure Drop through the filter housing is governed by the port, not the bowl length and the oil viscosity.

PRESSURE DROP THROUGH THE CLEAN FILTER ELEMENT

The Pressure Drop through the filter element is related both to the internal diameter of the filter element and to the filter media; this value is affected by the oil viscosity in a roughly proportional way: e.g. when the Dp value from the curve is 0,2 bar and a 46 cSt oil is used, the corresponding value is 0,31 ($=0,2 \times 46/30$) bar.

Housing FCR-7- 20/21/22

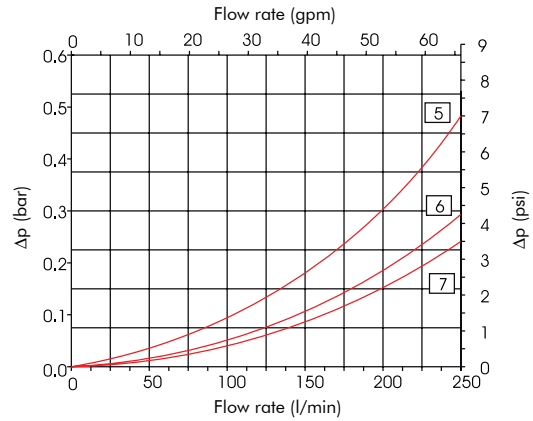

Element R-7-20

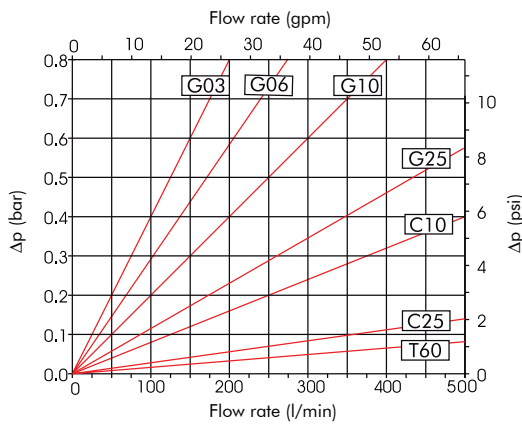

Element R-7-21

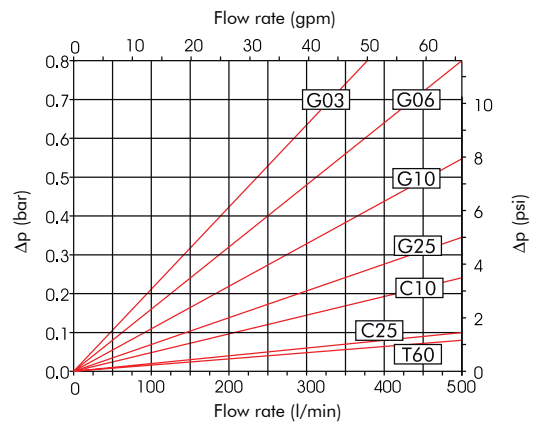

Element R-7-22

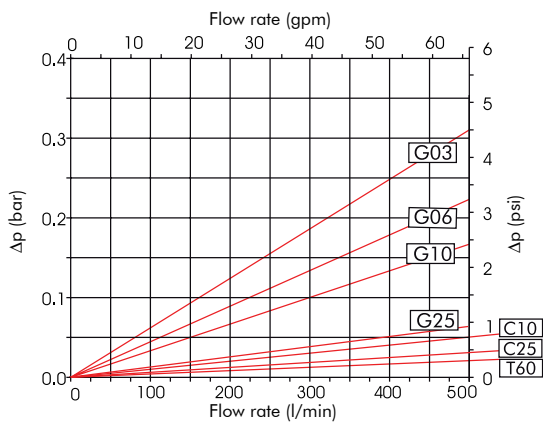

Pressure drop diagrams

PRESSURE DROP THROUGH THE FILTER HOUSING

The Pressure Drop through the filter housing is governed by the port, not the bowl length and the oil viscosity.

PRESSURE DROP THROUGH THE CLEAN FILTER ELEMENT

The Pressure Drop through the filter element is related both to the internal diameter of the filter element and to the filter media; this value is affected by the oil viscosity in a roughly proportional way: e.g. when the Δp value from the curve is 0,2 bar and a 46 cSt oil is used, the corresponding value is 0,31 ($=0,2 \times 46/30$) bar.

Housing FCR-7- 30/31/32/33

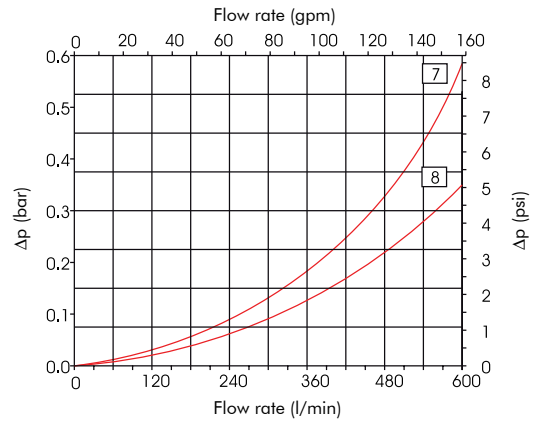

Element R-7-30

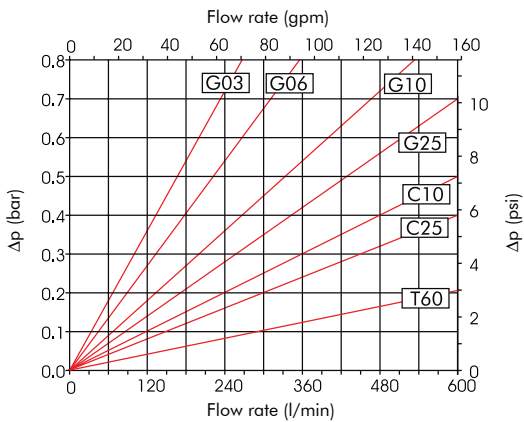

Element R-7-31

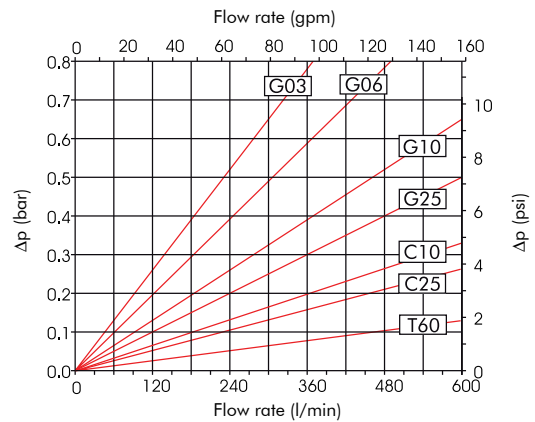

Element R-7-32

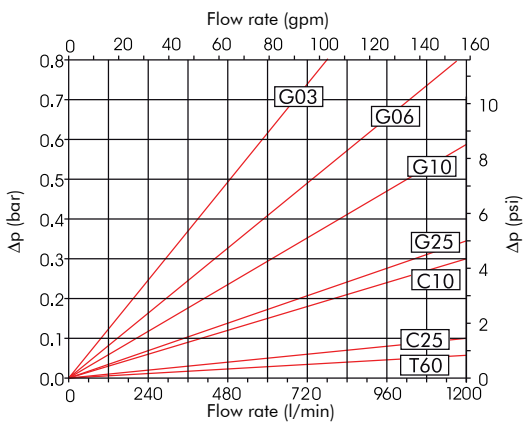

Element R-7-33

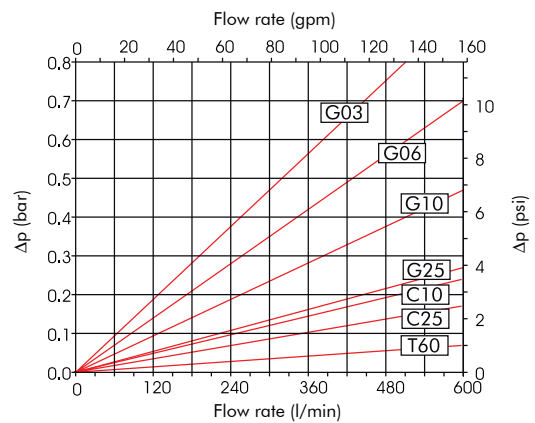

Pressure drop diagrams

PRESSURE DROP THROUGH THE BY-PASS VALVE

The by-pass valve is a safety device to prevent element collapse in case of differential pressure peaks due to flow peaks, cold start conditions or when the clogged element is not replaced in a timely manner.

By-pass FCR-7- 11/12/13/14

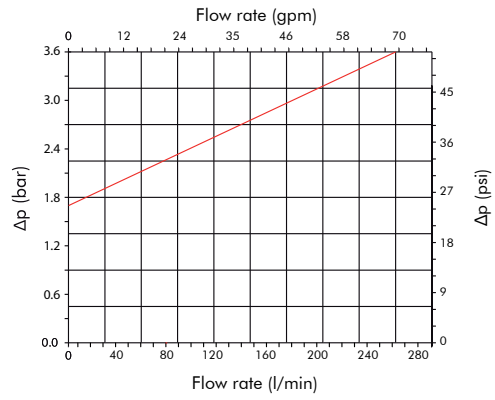

By-pass FCR-7- 20/21/22

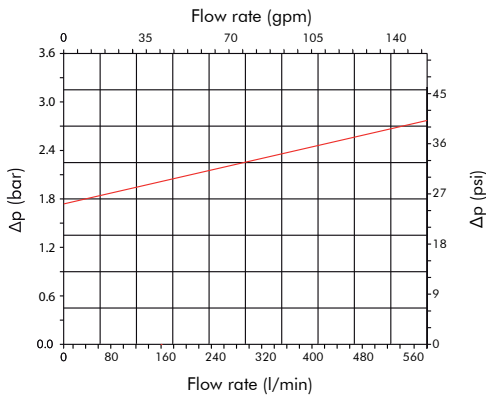

By-pass FCR-7- 30/31/32/33

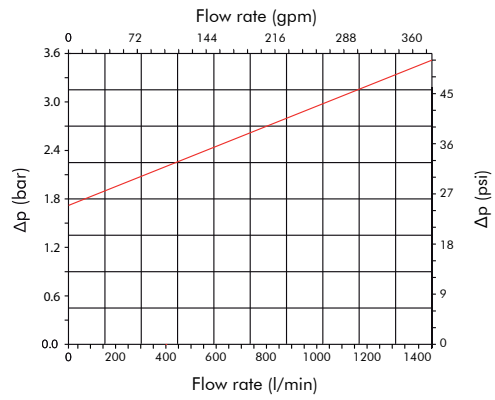

The above diagrams have been obtained at the FILTREC laboratory, according to the ISO 3968 specification, with mineral oil having 30 cSt viscosity and 0,86 Kg/dm³ density. In case of discrepancy, please check contamination level, viscosity and features of the oil in use and the sampling points of the differential pressure.

Clogging indicator

The Pressure Drop (Δp) through the filter increases during the system operation due to the contaminant retained by the filter element.

The filter element must be replaced when the indicator shows and before the Δp reaches the by-pass value setting. N.B. in cold start conditions a false alarm can be caused by higher oil viscosity due to low temperature; the indicator alarm must be considered at normal working temperature only.

The clogging indicator registers the pressure upstream the filter element:

- in the VISUAL indicator the red area shows the need for element replacement.
- in the ELECTRIC indicator an electrical switch is activated.

VISUAL PRESSURE GAUGE

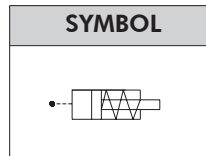
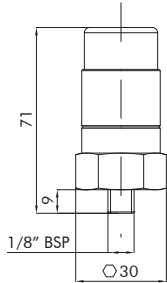

CODE	SETTING
R6	1,3 bar (18,9 psi)

PRESSURE/ VACUUM GAUGE

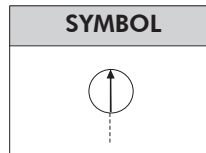
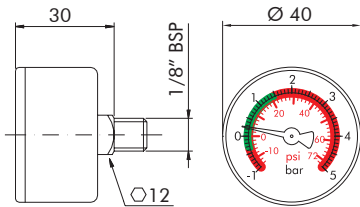

CODE	SCALE
R7	0 ÷ 1,4 bar (0 ÷ 20 psi) green sector
	1,4 ÷ 5 bar (20 ÷ 72,5 psi) red sector

Housing in black ABS material

N.B. Multipurpose product: this gauge can also be used as vacuum gauge on suction filters.

PRESSURE GAUGE

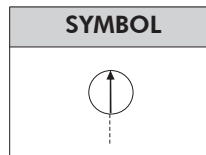
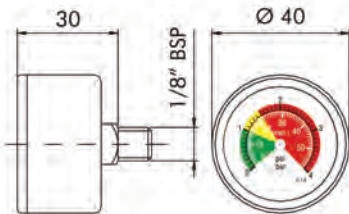

CODE	SCALE
R9	0 ÷ 1 bar (0 ÷ 14,5 psi) green sector
	1 ÷ 1,5 bar (14,5 ÷ 22 psi) yellow sector
	1,5 ÷ 4 bar (22 ÷ 58 psi) red sector

Housing in black ABS material

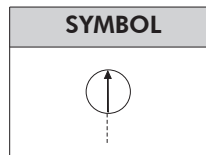

CODE	SCALE
R10	0 ÷ 1 bar (0 ÷ 14,5 psi) green sector
	1 ÷ 1,5 bar (14,5 ÷ 22 psi) yellow sector
	1,5 ÷ 4 bar (22 ÷ 58 psi) red sector

Housing in black ABS material

PRESSURE SWITCH

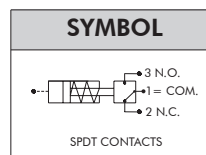
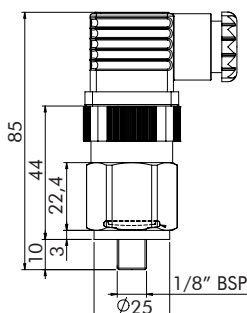

CODE	SETTING
R13	1,3 bar (18,9 psi)

PRESSURE SWITCH
1,3 bar (18,9 psi)

- DC: 30 V - 4 A inductive, 3 A resistive
- AC: 250 V - 3 A inductive, 2 A resistive
- Protection: IP65, connector DIN43650
- SPDT contacts

N.B. it can be used as N.O. contacts or N.C. contacts switch only, simply connecting 1 and 3 or 1 and 2 only, respectively.

Preferential option

User Tips

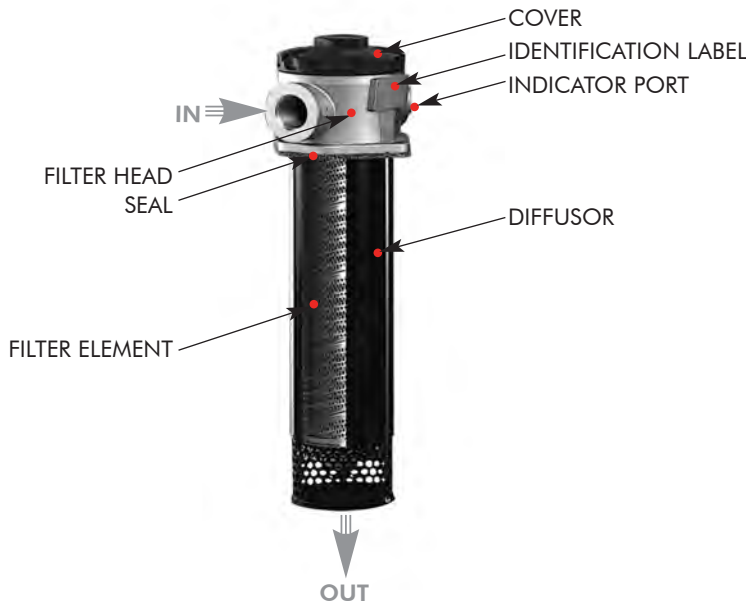

BOLTS / COVER TIGHTENING TORQUE	
FCR-7- 11/12/13/14	15 Nm
FCR-7- 20/21/22	5 Nm
FCR-7- 30/31/32/33	5 Nm

INDICATOR TIGHTENING TORQUE	
R6/R7/R9/R10/R13	30 Nm

Installation

Make sure that the filter flange is well secured on the tank lid through the fixing holes and that the hose is properly connected to the IN port.

After mounting verify that no tension is present on the filter.

Make sure that enough space is available for filter element replacement and that the clogging indicator is in a easily viewable position. If an electrical indicator is used, make sure that it is properly wired.

We recommend the stocking of a spare FILTREC filter element for timely replacement when required.

Operation

Make sure that the filter works within the conditions of pressure, temperature and fluid compatibility given in the first page of this data sheet. The filter element must be replaced as soon as the clogging indicator signals at working temperature (in cold start conditions, oil temperature lower than 30°C, a false alarm can be given due to oil viscosity). If no clogging indicator is mounted, make sure that the filter element is replaced according to the system manufacturer's recommendations.

Maintenance

Before removing the top cover, ensure that the system is switched off and there is no residual pressure in the filter.

Remove the top cover by unscrewing the fixing bolts. Remove the spring first and extract the insert assembly (warning : a certain quantity of oil can be retained within the filter element, provide to have a proper container available for it); unscrew the nut at the bottom of the insert and slip the dirty filter element carefully. Clean the tie rod (and the magnets if present) and check the support gaskets conditions, replace them if necessary. Fit a new FILTREC element (verify first the part number, particularly concerning the micron rating; open the plastic protection of the element from the the top and fit the element over the tie rod, then remove completely the plastic protection) and block it by tightening the bottom nut. Put the insert assembly into the head, put the spring in its position over the insert support, then mount the top cover and tighten properly the fixing bolts.

N.B. The used filter elements cannot be cleaned and re-used.

PED Compliance

FCR-7 filters conform to PED 97/23/CE norm, article 3 section 3, and so they can be used with fluids of group 2 (liquids with steam pressure < 0,5 bar at the maximum allowable temperature, article 3, section 1.1(b) – sub-section II).

WARNING

Make sure that Personal Protective Equipment (PPE) is worn during installation and maintenance operation.

Disposal of filter elements

The used filter elements and the filter parts dirty of oil are classified as "Dangerous waste material": they must be disposed according to the local laws by authorized Companies.



FCR-7 series

www.filtrec.com

