

Series HDD 601-1351

DN50 PN315

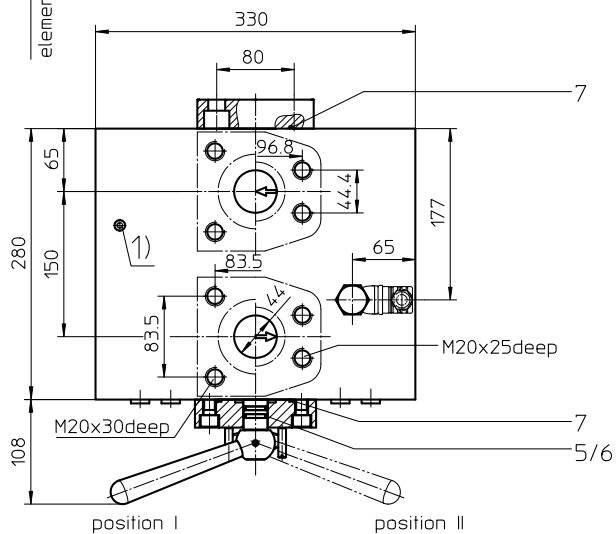
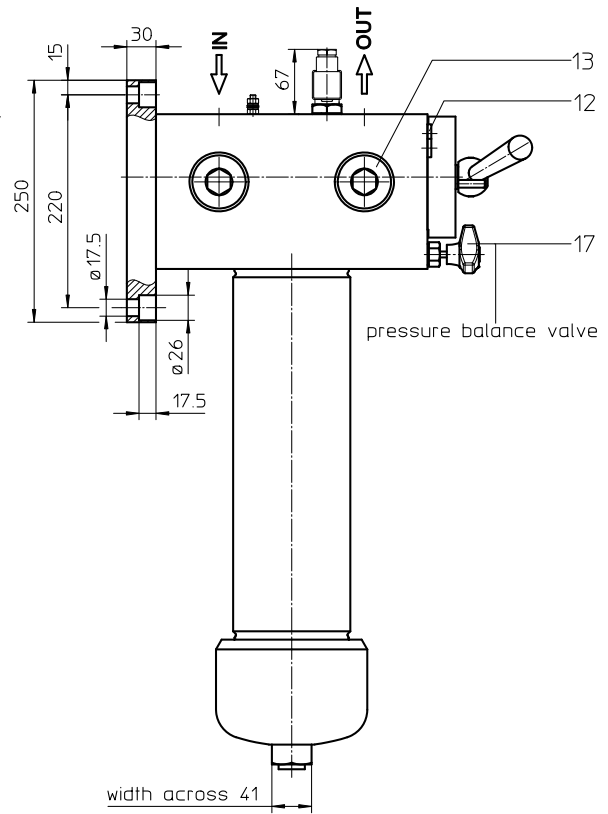
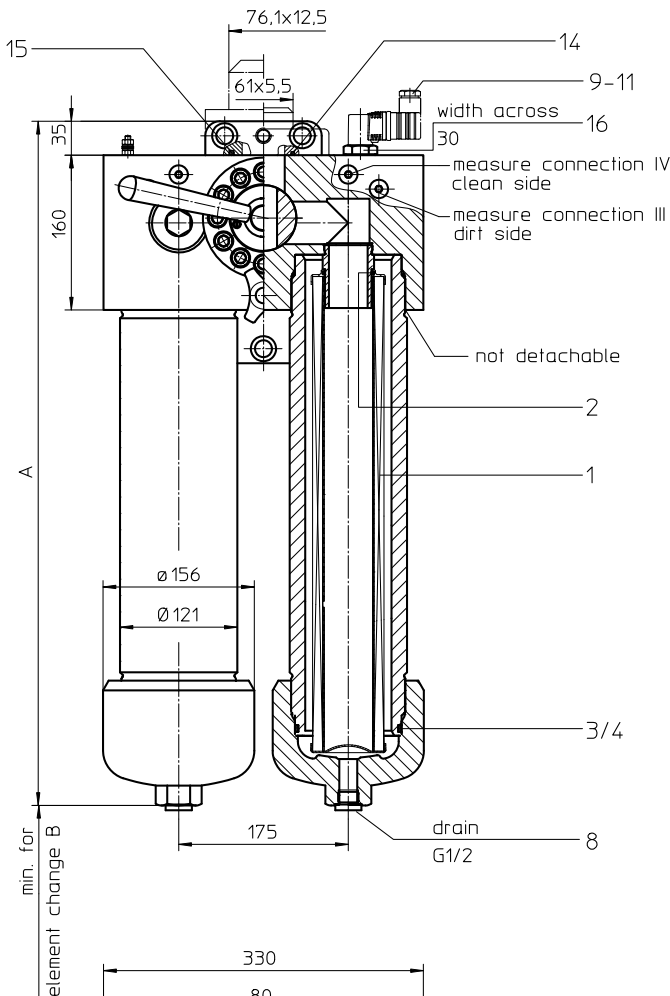

Dimensions:

type	HDD 601	HDD 901	HDD 1351
connection	2"		
A	557	707	955
B	310	460	710
weight kg	145	158	182
volume tank	2x 2,1 l	2x 3,1 l	2x 4,6 l

- 1) Connection for the potential equalization, only for application in the explosive area.

Measure connections III and IV to be used for pressure relief and air bleeding respective filter side.

Position I: left filter side in operation
Position II: right filter side in operation

Dimensions: mm

Designs and performance values are subject to change.



Powering Business Worldwide

Pressure Filter, change over Series HDD 601-1351 DN50 PN315

Description:

Pressure filters changeover series HDD 601-1351 are suitable for operating pressure up to 315 bar. The pressure peaks are absorbed by a sufficient margin of safety.

Duplex filters can be maintained without interruption. The upper part has a three-way-change-over valve which allows to change-over the flow from the dirty filter-side to the clean filter-side without interrupting the operation. The change-over procedure does not lead to a reduction of area.

The change-over can be done easily by opening of the change-over valve.

The mini-measuring connections on each filter-side allow the measuring of the pressure drop through the filter element, as well as at the pressure discharge of the tube plug during the maintenance. Filter elements are available down to a filter fineness of 4 µm(c).

For cleaning the stainless steel mesh element (see special leaflets 21070-4 and 39448-4) or changing the filter element, remove the tube plug and take out the element. The mesh elements are not guaranteed to maintain 100% performance after cleaning.

Eaton filter elements are known for high intrinsic stability and an excellent filtration capability, a high dirt-retaining capacity and a long service life.

Eaton filter elements are available up to a pressure resistance of Δp 160 bar and a rupture strength of Δp 250 bar.

Eaton filter can be used for petroleum-based fluids, HW emulsions, water glycols, most synthetic fluids and lubrication fluids. Consult factory for specific fluid applications.

The internal valve is integrated into the filter head. After reaching the bypass pressure setting, the bypass valve will send unfiltered partial flow around the filter.

The reversing valve provides another level of protection for the filter element. The reverse flow will not be filtered.

Type index:

Complete filter: (ordering example)

HDD.	901.	10VG.	HR.	E.	P.	-.	FS.	8.	-.	-.	AE
1	2	3	4	5	6	7	8	9	10	11	12

- | | |
|----|--|
| 1 | series:
HDD = pressure filter change over |
| 2 | nominal size: 601, 901, 1351 |
| 3 | filter material:
80G, 40G, 25G stainless steel wire mesh
25VG, 16VG, 10VG, 6VG, 3VG microglass |
| 4 | filter element collapse rating:
30 = Δp 30 bar
HR = Δp 160 bar (rupture strength Δp 250 bar) |
| 5 | filter element design:
E = single-end open |
| 6 | sealing material:
P = Nitrile (NBR)
V = Viton (FPM) |
| 7 | filter element specification:
- = standard
VA = stainless steel |
| 8 | process connection:
FS = SAE-flange connection 6000 PSI (standard)
FV = AVIT-flange connection 320 bar (special design) |
| 9 | process connection size:
8 = 2" |
| 10 | filter housing specification:
- = standard |
| 11 | internal valve:
- = without
S1 = with bypass valve Δp 3,5 bar
S2 = with bypass valve Δp 7,0 bar
R = reversing valve, Q ≤ 465,384 l/min |
| 12 | clogging indicator or clogging sensor:
- = without
AOR = visual, see sheet-no. 1606
AOC = visual, see sheet-no. 1606
AE = visual-electric, see sheet-no. 1615
VS5 = electronic, see sheet-no. 1619 |

To add an indicator/sensor to your filter, use the corresponding indicator data sheet to find the indicator details and add them to the filter assembly model code.

Filter element: (ordering example)

01E.	900.	10VG.	HR.	E.	P.	-
1	2	3	4	5	6	7

- | | |
|---|--|
| 1 | series:
01E = filter element according to company standard |
| 2 | nominal size: 600, 900, 1350 |
| 3 | - 7 see type index-complete filter |

Accessories:

- gauge port- and bleeder connections, see sheet-no. 1650
- SAE-counter flange, see sheet-no. 1652
- AVIT-counter flange, see sheet-no. 1654

Technical data:

operating temperature:	-10 °C to +100 °C
operating medium:	mineral oil, other media on request
max. operating pressure:	315 bar
test pressure:	450 bar
process connection:	SAE-flange 6000 PSI (standard) or AVIT-flange 320 bar (special design)
housing material:	C-steel
sealing material:	Nitrile (NBR) or Viton (FPM), other materials on request
installation position:	vertical
bleeder- and measuring connections:	G ¼

Classified under the Pressure Equipment Directive 2014/68/EU for mineral oil (fluid group 2), Article 4, Para. 3.
Classified under ATEX Directive 2014/34/EU according to specific application (see questionnaire sheet-no. 34279-4).

Pressure drop flow curves:

Filter calculation/sizing

The pressure drop of the assembly at a given flow rate Q is the sum of the housing Δp and the element Δp and is calculated as follows:

$$\Delta p_{assembly} = \Delta p_{housing} + \Delta p_{element}$$

$$\Delta p_{housing} = (\text{see } \Delta p = f(Q) \text{ - characteristics})$$

$$\Delta p_{Element} (mbar) = Q \left(\frac{l}{min} \right) \times \frac{MSK}{10} \left(\frac{mbar}{l/min} \right) \times v \left(\frac{mm^2}{s} \right) \times \frac{p}{0,876} \left(\frac{kg}{dm^3} \right)$$

For ease of calculation our Filter Selection tool is available online at
www.eatonpowersource.com/calculators/filtration/

Material gradient coefficients (MSK) for filter elements

The material gradient coefficients in mbar/(l/min) apply to mineral oil (HLP) with a density of 0,876 kg/dm³ and a kinematic viscosity of 30 mm²/s (139 SUS). The pressure drop changes proportionally to the change in kinematic viscosity and density.

HDD	VG					G		
	3VG	6VG	10VG	16VG	25VG	25G	40G	80G
601	0,776	0,539	0,345	0,300	0,205	0,0247	0,0231	0,0158
901	0,538	0,374	0,239	0,208	0,142	0,0155	0,0144	0,0099
1351	0,336	0,233	0,149	0,130	0,089	0,0100	0,0093	0,0064

$\Delta p = f(Q)$ – characteristics according to ISO 3968

The pressure drop characteristics apply to mineral oil (HLP) with a density of 0,876 kg/dm³. The pressure drop changes proportionally to the density.

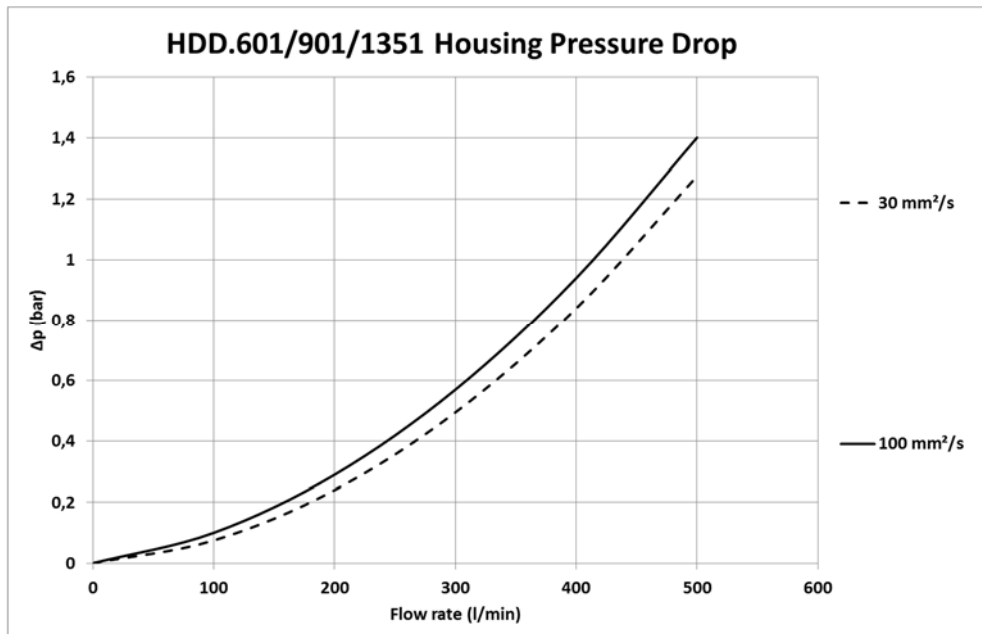

Symbols:

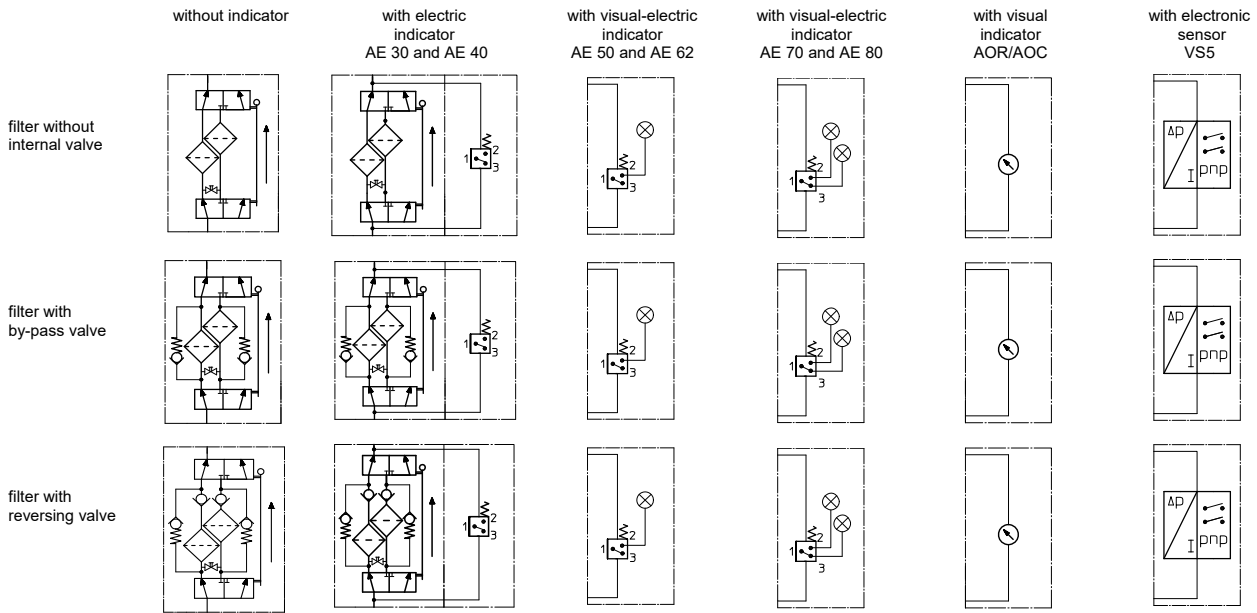

Spare parts:

item	qty.	designation	dimension			article-no.	
			HDD 601 01E.600...	HDD 901 01E.900...	HDD 1351 01E.1350...		
1	2	filter element					
2	2	O-ring		48 x 3		304357 (NBR)	304404 (FPM)
3	2	O-ring		98 x 4		301914 (NBR)	304765 (FPM)
4	2	support ring		110 x 3,5 x 2		304802	
5	2	O-ring		18 x 3		304359 (NBR)	304399 (FPM)
6	2	support ring		25 x 2,5 x 0,5		311311	
7	2	O-ring		71 x 3		306451 (NBR)	306897 (FPM)
8	2	screw plug		G 1/2		304678	
9	1	clogging indicator, visual		AOR or AOC		see sheet-no. 1606	
10	1	clogging indicator, visual-electric		AE		see sheet-no. 1615	
11	1	clogging sensor, electronic		VS5		see sheet-no. 1619	
12	4	screw plug		G 1/4		305003	
13	8	screw plug		G 1 1/2		311475	
14	1	O-ring		56,75 x 3,53		306035 (NBR)	310264 (FPM)
15	1	O-ring		61 x 5			
16	1	screw plug		20913-4		309817	
17	1	pressure balance valve		DN10		305000	

item 16 execution only without clogging indicator or clogging sensor

Test methods:

Filter elements are tested according to the following ISO standards:

ISO 2941	Verification of collapse/burst resistance
ISO 2942	Verification of fabrication integrity
ISO 2943	Verification of material compatibility with fluids
ISO 3723	Method for end load test
ISO 3724	Verification of flow fatigue characteristics
ISO 3968	Evaluation of pressure drop versus flow characteristics
ISO 16889	Multi-pass method for evaluating filtration performance

North America
44 Apple Street
Tinton Falls, NJ 07724
Toll Free: 800 656-3344
(North America only)
Tel: +1 732 212-4700

China
No. 3, Lane 280,
Linhong Road
Changning District, 200335
Shanghai, P.R. China
Tel: +86 21 5200-0099

Europe/Africa/Middle East
Auf der Heide 2
53947 Nettersheim, Germany
Tel: +49 2486 809-0

Friedensstraße 41
68804 Altlufheim, Germany
Tel: +49 6205 2094-0

An den Nahewiesen 24
55450 Langenlonsheim, Germany
Tel: +49 6704 204-0

Singapore
100G Pasir Panjang Road #07-08
Singapore 118523
Tel: +65 6825-1668

Brazil
Av. Ermano Marchetti, 1435 -
Água Branca, São Paulo - SP,
05038-001, Brazil
Tel: +55 11 3616-8461

**For more information, please
email us at filtration@eaton.com
or visit www.eaton.com/filtration**

© 2019 Eaton. All rights reserved. All trademarks and registered trademarks are the property of their respective owners. All information and recommendations appearing in this brochure concerning the use of products described herein are based on tests believed to be reliable. However, it is the user's responsibility to determine the suitability for his own use of such products. Since the actual use by others is beyond our control, no guarantee, expressed or implied, is made by Eaton as to the effects of such use or the results to be obtained. Eaton assumes no liability arising out of the use by others of such products. Nor is the information herein to be construed as absolutely complete, since additional information may be necessary or desirable when particular or exceptional conditions or circumstances exist or because of applicable laws or government regulations.