



LOFMEM™ TFA Fluoropolymer Pleated Cartridge Filter

Eaton's LOFMEM TFA filters are designed to resist the most severe chemical exposure environments, making them the preferred choice for demanding high temperature and chemical process applications. LOFMEM TFA is designed for use with strong acids, bases, organic chemicals and oxidizers.

LOFMEM TFA membrane filter cartridges use absolute rated PTFE membrane combined with PTFE support layers and PFA hardware to create a 100% fluoropolymer pleated cartridge filter suitable for use in the most demanding environments. LOFMEM TFA is manufactured without the use of glues, adhesives or wetting agents, ensuring high purity in every application.

Features and benefits

- PTFE membrane
- Superior chemical resistance
- Absolute rated filtration
- All-thermal bonded construction, no adhesives
- No wetting agents
- Available in multiple configurations

Design

Filter material
PTFE membrane

Inner core, cage, end caps
PFA

Support layers
PTFE

Gaskets/O-rings
FEP encapsulated (O-Rings only), FPM

End Adapter
222/Flat single open end

Retention ratings
0.1, 0.2, 0.45, 1 µm

Technical data

Nominal lengths
10", 20", 30", 40"
(254, 508, 762, 1016 mm)

Outside diameter
2.7" (69 mm)

Inside diameter
1.1" (27.9 mm)

Surface area
5.2 ft² (0.48 m²) per 10" element

Max. operating temperature
338 °F (170 °C)



Powering Business Worldwide

LOFMEM TFA membrane filter cartridges

Flow rate

(68°F/20 °C per 10" filter cartridge for water)

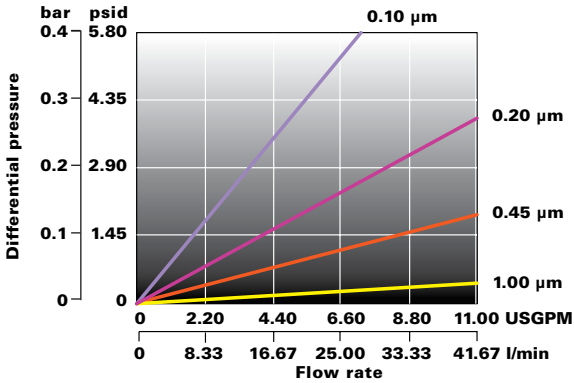

Performance specifications

Steam/autoclave

Filter cartridges will withstand at least 50 steam/autoclave 1 hour cycles @ 135 °C

Integrity test values per 10" filter cartridge

Air Diffusion per 10-inch filter cartridge wet with 60/40 IPA/water. Contact Eaton for specific method.

Pore size	Specification
0.1 µm:	≤ 50 cc/min @ 1.2 bar
0.2 µm:	≤ 20 cc/min @ 0.8 bar
0.45 µm:	≤ 15 cc/min @ 0.34 bar
1 µm:	≤ 15 cc/min @ 0.2 bar

* For liquids other than water, multiply pressure drop by fluid viscosity in centipoise.

Ordering code

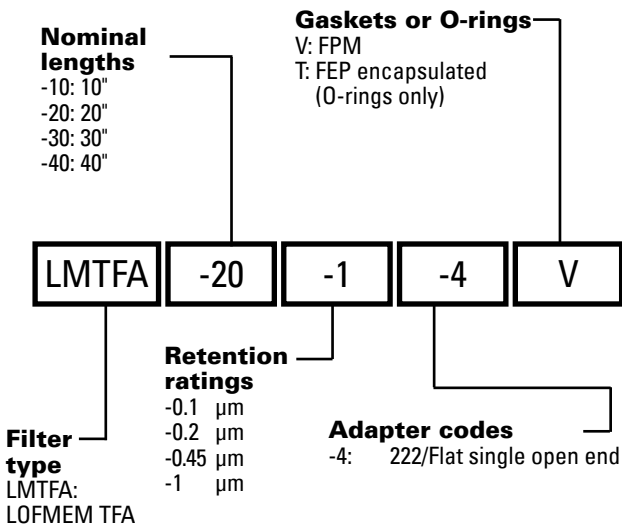

North America
44 Apple Street
Tinton Falls, NJ 07724
Toll Free: 800 656-3344
(North America only)
Tel: +1 732 212-4700

Europe/Africa/Middle East
Auf der Heide 2
53947 Nettersheim, Germany
Tel: +49 2486 809-0

Friedensstraße 41
68804 Altlußheim, Germany
Tel: +49 6205 2094-0
An den Nahewiesen 24
55450 Langenlonsheim, Germany
Tel: +49 6704 204-0

China
No. 3, Lane 280,
Linhong Road
Changning District, 200335
Shanghai, P.R. China
Tel: +65 21 5200-0099

Singapore
100G Pasir Panjang Road #07-08
Singapore 118523
Tel: +65 6825-1668

Brazil
Rua Clark, 2061 - Macuco
13279-400 - Valinhos, Brazil
Tel: +55 11 3616-8400

For more information, please email us at filtration@eaton.com or visit www.eaton.com/filtration

© 2018 Eaton. All rights reserved. All trademarks and registered trademarks are the property of their respective owners. All information and recommendations appearing in this brochure concerning the use of products described herein are based on tests believed to be reliable. However, it is the user's responsibility to determine the suitability for his own use of such products. Since the actual use by others is beyond our control, no guarantee, expressed or implied, is made by Eaton as to the effects of such use or the results to be obtained. Eaton assumes no liability arising out of the use by others of such products. Nor is the information herein to be construed as absolutely complete, since additional information may be necessary or desirable when particular or exceptional conditions or circumstances exist or because of applicable laws or government regulations.

EN
EF-LMTFA
05-2018