

Guardian

Portable Hydraulic Filtration Systems

Max. 15 l/min - 3.4 bar



Making portable system cleanliness available all the time

A 'use anywhere' fluid transfer solution

The Guardian portable filtration system is designed to 'clean' new oil and deliver it to a system or carry out a clean up of used fluid to its original condition. Maximum pressure 3.4 bar. Maximum flow 15 l/min. A water removal element option is also available.



Contact Information:

Parker Hannifin
Hydraulic Filter Division Europe

European Product Information Centre
Freephone: 00800 27 27 5374
(from AT, BE, CH, CZ, DE, EE, ES, FI, FR, IE, IT, PT, SE, SK, UK)
filtrationinfo@parker.com

www.parker.com/hfde

Product Features:

- Guardian is designed to 'clean' new oil and deliver it to a system.
- Carries out a clean up of existing fluid to its original condition.
- Maximum pressure 3.4 bar. Maximum flow 15 l/min.
- Filters petroleum based oils, water emulsions and diesel fuels.

Guardian

Portable Hydraulic Filtration Systems

Features & Benefits

Features	Advantages
Portable and robust design	Guardian is designed to be used anywhere. Take it to the system or transfer new oil from the drum.
Lightweight design	Only 10.6 kg
Quick disconnect hose connections	Storage is simple. Guardian's compact design means it is easily stowed.
Visual indicator	Operational condition is constantly monitored
110VAC or 220/240VAC options	Guardian's power flexibility means it can be used anywhere.
A range of clean-up elements	A user can specify the media that will best achieve his clean up/filtering requirements.
Water removal element option	Water removal from the system is an important requirement for fluid efficiency.

Note: 15 l/min / Fluid transfer at a controlled rate

- Fluid transfer
- Offline reservoir clean-up
- Injection moulding machines
- Royal navy surface fleet systems
- Paper mills
- Industrial equipment
- Mobile equipment
- Marine system support

The Parker Filtration Guardian portable filtration systems.

Guardian is a portable filtration system with two main functions: to ensure that new 'dirty' fluid often contaminated during handling, is delivered to the system at a specific cleanliness; and to permit periodic clean up of existing fluid to original condition.

Recommended fluids: Petroleum based oils, water emulsions and diesel fuels.

Application Example

A hydraulic system reservoir had become heavily contaminated and the hydraulic system was in danger of a catastrophic failure from particulate and water contamination. These contaminants were introduced from various points – airborne, wear and introduction of new 'dirty' fluids. The Guardian filtration system was installed into the hydraulic systems reservoir and run completely off-line for a period of time until acceptable contamination levels were achieved.

This off-line attachment allowed the hydraulic system to continue operating without costly downtimes. Additionally a Water Removal (WR) Element was also fitted to the Guardian, which radically reduced the water contamination within the entire system.

This customer will 'only now' introduce new fluids into his hydraulic application by using the Guardian filtration system and in addition utilises the Guardian off-line option to maintain and protect his system.

Contamination levels are monitored by an LCM202022 which controls the Guardians operation.

Result: reliability and complete confidence restored.



Specification

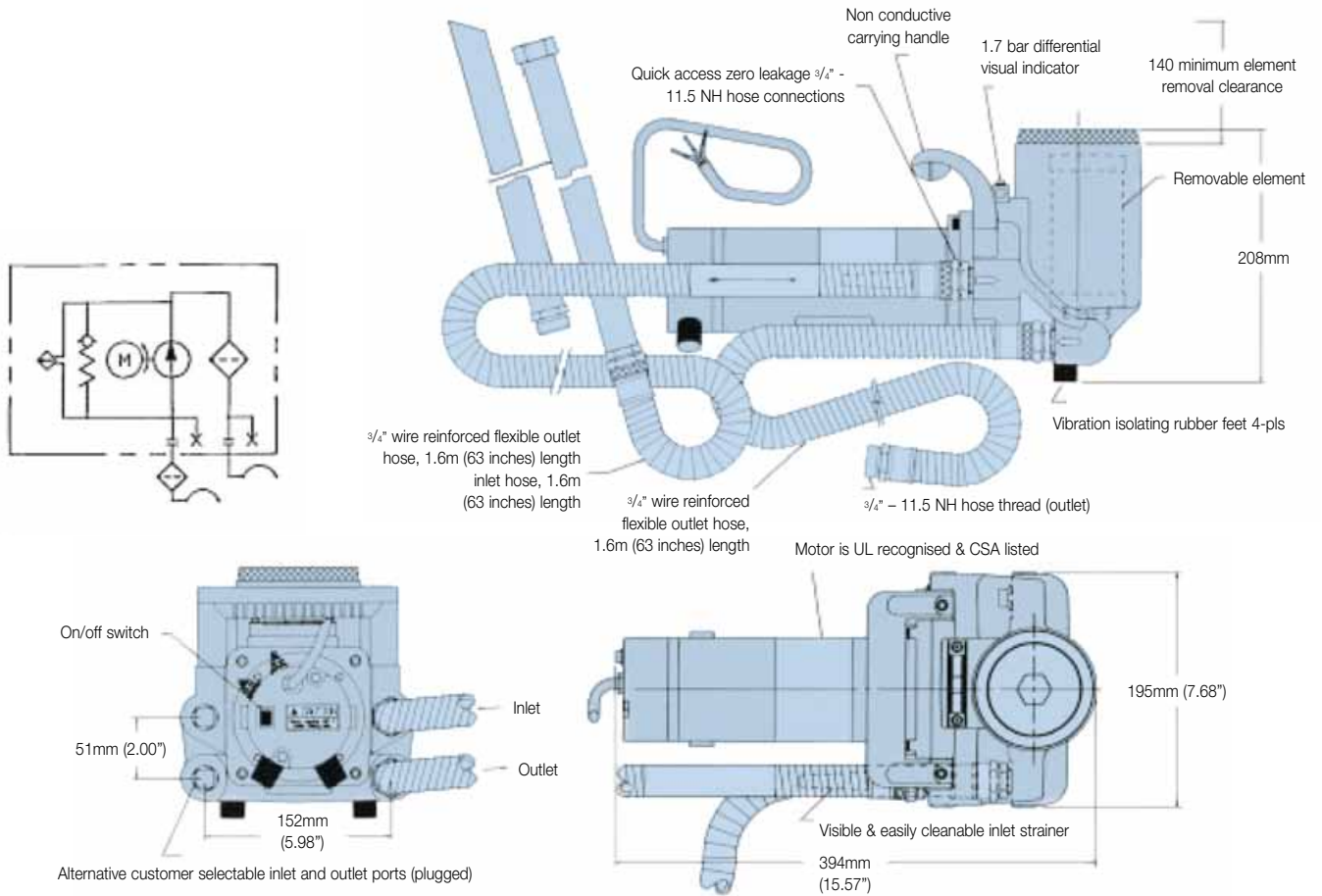

Guardian

Portable Hydraulic Filtration Systems

Ordering Information and Product Configurator

Standard products table

Part number	Supersedes	Model (fluorocarbon)	Motor option	Element (μ)	Options	Plug type	Replacement element
GT4E110Q1UK	F3-GT4E-1-10Q-1-UK	GT4E	1	10Q	1	UK	G04396Q
GT4E110Q1EUR	F3-GT4E-1-10Q-1-EUR	GT4E	1	10Q	1	EUR	G04396Q
GT4E210Q1IND	F3-GT4E-2-10Q-1-IND	GT4E	2	10Q	1	IND	G04396Q

Note 1: Motor Options*

Option 1 = 220/240 VAC

Option 2 = 110 VAC.

Note 2: Plug Type**

IND = Industrial 110VAC UK Option.

Note 3: (Options) Quick disconnect hose connections are available. Consult Parker.

Note 4: The 24 Volt motor option is available. For details consult Parker.

Replacement elements

Guardian replacement elements to ISO16889

Part number	Media code	Media type
G04396Q	10Q	Microglass III
G04394Q	02Q	Microglass III
G04395Q	05Q	Microglass III
G04397Q	20Q	Microglass III
G04400	25	Wire mesh
G04401	40	Wire mesh
G04402	74	Wire mesh
932019	WR	Water removal

Note 1: Part numbers featured with bold highlighted codes will ensure a 'standard' product selection.

Note 2: Alternate displayed part number selection will require you to contact Parker Filtration for availability.

Filtration Unit

Hydraulic Service Equipment

Max. 15 l/min - 6 bar



Permanent and offline fluid cleaning

Reliable fluid transfer from drum to system

The Filtration unit offers both permanent and offline fluid cleaning where higher levels of contamination are expected. Maximum pressure 6 bar. Maximum flow 15 l/min. Designed to take the unit to the application for maximum efficiency in use.



Contact Information:

Parker Hannifin
Hydraulic Filter Division Europe

**European Product
Information Centre**
Freephone: 00800 27 27 5374
(from AT, BE, CH, CZ, DE, EE, ES,
FI, FR, IE, IT, PT, SE, SK, UK)
filtrationinfo@parker.com

www.parker.com/hfde

Product Features:

- Filtration unit offers both permanent and offline fluid cleaning where higher levels of contamination are expected.
- Lightweight design. Spin-on 10 micron Abs. element.
- Maximum pressure 6 bar. Maximum flow 15 l/min.
- Robust construction.

Filtration Unit

Hydraulic Service Equipment

Features & Benefits

Features	Advantages	Benefits
Single phase and three phase motor options	Flexibility of power output	End user choice dependent on application
15 l/min flow	Fluid transfer at a controlled rate	Reliable fluid transfer from drum to system
Red/green visual indicator	Clear indication of condition during operation	High visibility during operation
Robust construction	Reliability designed in	Designed to be used even in the most demanding conditions
Spin-on element	Easy change element	10 micron Abs. elements
Lightweight design	Easy to locate when and where required	Take the unit to the application. It's that easy

Typical Applications

- Fluid transfer
- Small lubrication systems
- Constant flushing loops
- Maintenance flushing
- Offline filtration in circuits where pressure and flow pulses are expected

The Parker Filtration Service Equipment.

Designed to offer both permanent and offline cleaning where higher levels of contamination are expected and portable additional clean-up capability as part of your preventative maintenance package.



Specification

Electric motor

Frame Size: IEC Frame 63. Foot and flange 'D' (Flange IEC.F115). Totally enclosed fan cooled.

Windings: 380/420 volt 3 ph/50 Hz, 220 Volt 1 ph/50 Hz 110 Volt 1 ph/50 Hz.

Power: 0.18 kW (1/4 hp).

Speed: 1400 rev/min.

It is recommended that the Unit is wired independently from the main system when permanently installed, to facilitate the simple changing of the filter element without interrupting the main system.

Filtration unit description

The Parker 'Filtration Unit' consists of an electric motor directly coupled to a hydraulic pump, which has a built in bypass fitted and spin on filter element. Fluid drawn in at pump inlet is circulated through the filter element and is thus cleaned before being delivered from the outlet port. A built in bypass valve safeguards the element in the event of blockage and returns oil to the pump inlet, this ensures that all fluid output from the unit is filtered, whatever the operating conditions. A visual element condition indicator is fitted to the pump. A unit is available without electric motor for customers who prefer to supply their own. See installation notes and part numbers for ordering.

Pump and bypass valve

Pump: Lobe type for quiet running.

Flow: 15 l/min.

Connections: Inlet G¹/₂ (1/2" BSP).
Outlet G³/₈ (3/8" BSP).

Bypass Valve: Cracks at 1.5 bar approximately. Bypassed oil is recirculated within the pump. Bypassed oil is reintroduced into the inlet port and does not pass the filter. Bypass operates when the element is contaminated and needs replacing. This condition will be made clear by the visual indicator. The Bypass Valve could also open when being used with high viscosity fluids, thus effectively reducing the unit output.

Filter and condition indicator

Filter Type: Rapid replacement spin-on can with 10µ cellulose element. Ensure that end clearance (20mm) is available to permit element withdrawal. 10µ absolute. MXR8550

Visual indicator

Has green and red zones on the dial. Needle in the green zone indicates normal operation. When the needle enters the red zone, the bypass valve will permit a flow of oil to return to the pump inlet – The element will then need to be replaced. The bypass is fully open when the needle is at the extreme of the red sector.

Sound level

The Filtration Unit under normal conditions will operate at a sound pressure level of approximately 65 dBA.

Installation Details

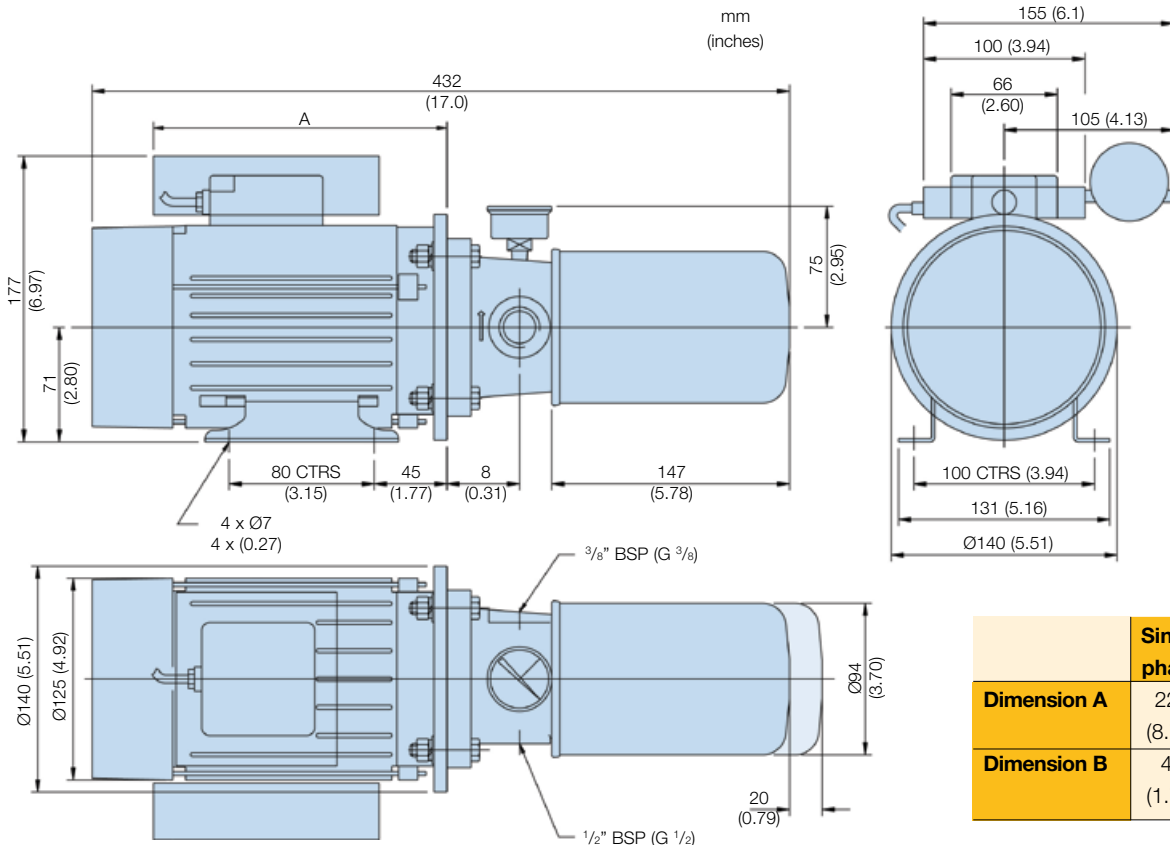

Filtration Unit

Hydraulic Service Equipment

Sectioned Detail

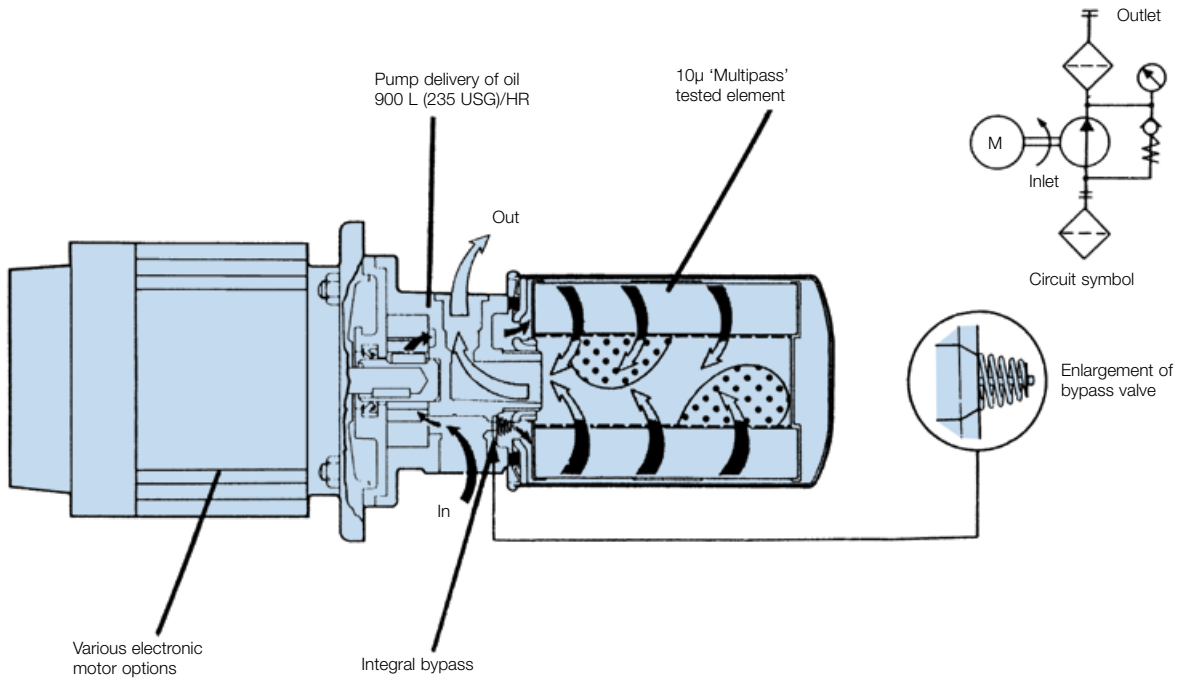

Installation and Operational Notes

The Filtration Unit is suitable for mineral based oils. Maximum viscosity at start up condition 850 centistokes-minimum viscosity 8 centistokes. Note that at 850 centistokes output will be reduced due to opening of bypass. Maximum operating temperature +90°C (194°F).

The inlet pipe should be as large and as short as convenient to reduce inlet depression to a minimum. It should not be less than 12mm (0.47") internal diameter.

Suction element SE7511110 is supplied with all assemblies and must be installed. Ensure that a minimum 75mm (2.95") head of oil is maintained above the suction element.

The outlet pipe should be as large as possible to reduce the possibility of delivery pressure exceeding the bypass valve setting. It should not be less than 10mm (0.39") internal diameter. The discharge end of this pipe should always be below the oil surface to minimise aeration. It is equally important, to ensure the ends of the inlet and outlet pipes are as far apart as possible. It is recommended that a baffle be positioned between the suction and return pipes, to give maximum circulation of oil.

Installation details – 2742

The Filtration Unit is available without an electrical motor, any type motor may be used of identical frame, flange and shaft size to that stated in the specification. Remove the key, fitted to electric motor shaft. There are four nuts and bolts M8-1.25mm thread supplied loose, the pump housing is complete with a shaft adaptor with internal drive pin.

To fit pump to electric motor simply insert drive shaft of motor into the pump drive adaptor ensuring the drive pin engages in shaft keyway and that the locating spigot are correctly engaged. Complete the assembly by fitting the four nuts, bolts and washers.

Ideal Application

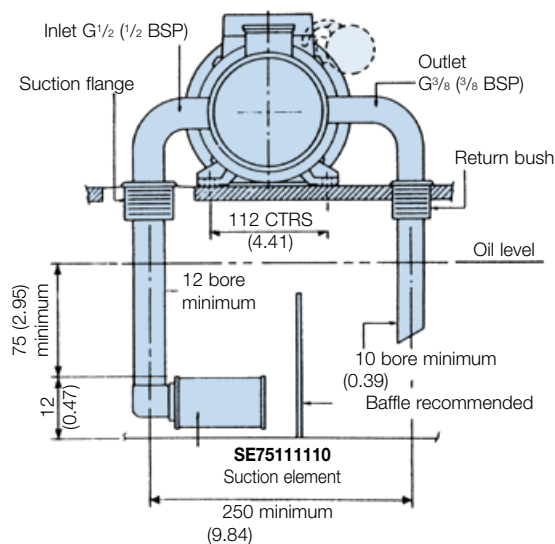
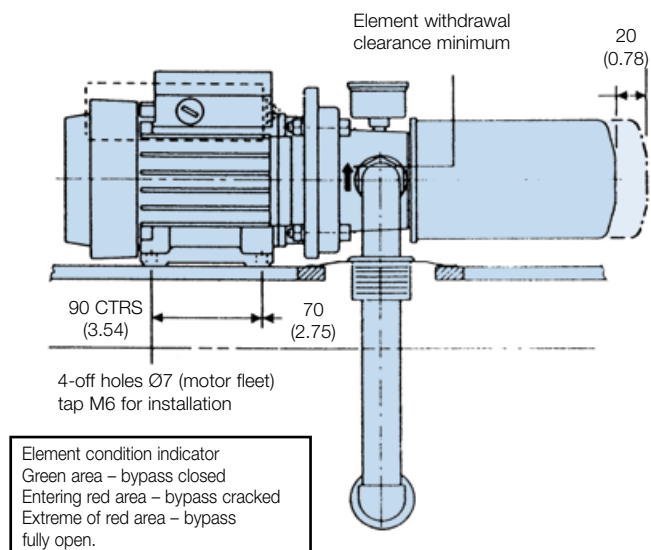

Ordering Information

Standard products table

Part number	Description	Weight	Replacement elements
2741	10µ abs. filtration pump complete with 3 phase electric motor (380/420/50 Hz H.E.F.C class F) visual indicator	5.92 Kg (13.02 lbs)	MXR8550 (10µ abs.)
2742	10µ abs. filtration pump without electric motor (supplied with 4 x nuts, bolts and washers) visual indicator	1.50 Kg (3.3 lbs)	
2743	10µ abs. filtration pump complete with single phase electric motor (220/50 Hz T.E.F.C class F) visual indicator	6.20 Kg (13.64 lbs)	
2744	10µ abs. filtration pump complete with single phase electric motor (110/50 Hz T.E.F.C class F) visual indicator	6.20 Kg (13.64 lbs)	

Note 1: Part numbers featured with bold highlighted codes will ensure a 'standard' product selection

Note 2: Alternate displayed part number selection will require you to contact Parker Filtration for Availability