

HDB Bag filter housing



HDB series of filterbag housings represent the line of economical yet heavy duty vessels used in various industries and applications:

- paint
- automotive
- chemical
- petrochemical
- food and beverages
- power
- other

HDB housing, having a side entry is a classical construction, proven in thousands world-wide applications. It's robust design, selection of materials of constructions and finishes make it ideal for most applications. It accepts all standard filterbags with metal ring or plastic self sealing collar, size 2 (7"/32") or 1 (7"/16").

It is designed and manufactured according to EEC directive PED 97/23/EC for group 2 liquids, under category SEP. It can be used for filtration of "non dangerous substances" as understood by this directive and comprises most common process streams. Standard design pressure is 8 bars at T=60°C.

HDB housings can be executed in two basic finishes: industrial - glass beaded (satin) and with mirror polish finish for more demanding applications. Standard construction materials are AISI 304, AISI 316 and 316L.

Construction materials

- AISI 304
- AISI 316L
- Titanium
- Other

Standard parameters

Max. working temperature	: 100°C
Max. pressure difference	: 10 bar



HDB Bag filter housing

PRODUCT MAIN FEATURES

Pressure ratings:

- 8 bar
- 10 bar
- 16 bar

Wide selection of connections:

- threaded
- flanged
- DIN quick couplings
- Tri-Clamp
- Butt weld
- camlock

Finishes:

- Mirror polish
- Satin : glass beaded
- electropolished

Swing bolt closure with eye nuts and hinge made of ss

Adjustable tripod ss legs

INLET - OUTLET CONFIGURATION

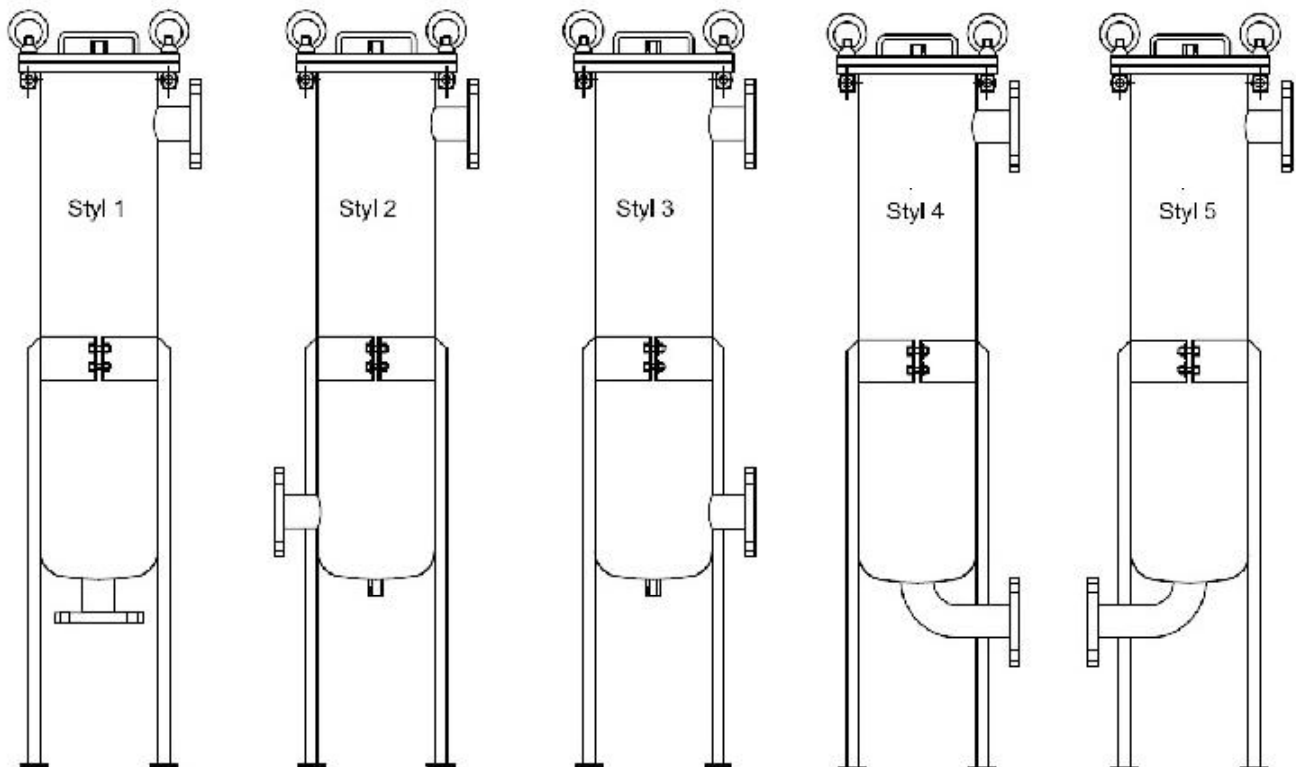

HDB Bag filter housing

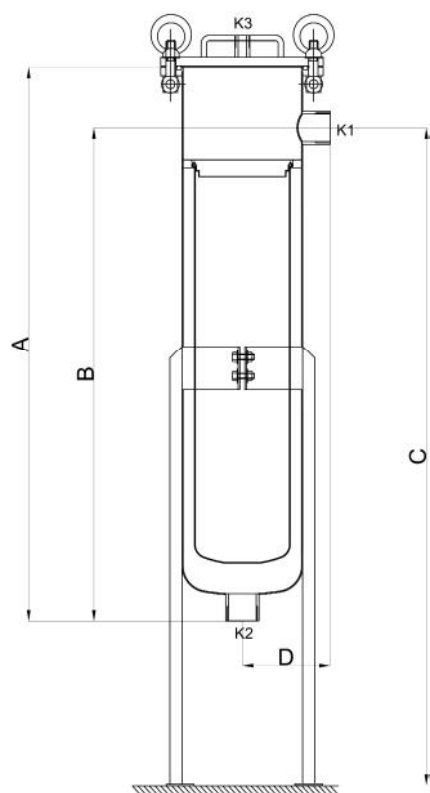

Size	A	B	C		D
			min.	max.	
#2	980	855	980	1350	155
#1	605	480	735	970	155
#4	578	448	-	-	125
#3	430	308	-	-	125

Ordering information

Type	Size of bag	Material	Body seal	Finish	Connection size	Connection type
HDB	2 = 7"/32"	04 = AISI 304	B = NBR	S = Satin (glass beaded)	DN 25	BSP = Thread
	1 = 7"/16"	06 = AISI 316	E = EPDM		DN 40	FL = Flanged
	4 = 4"/8,5"		S = Silicone	P = mechanical polish	DN 50	TC = Tri-Clamp
	XL = 9"/32"		V = Viton	EP = electropolished	DN 65	FT = Butt weld
						DIN = Quick release coupling